

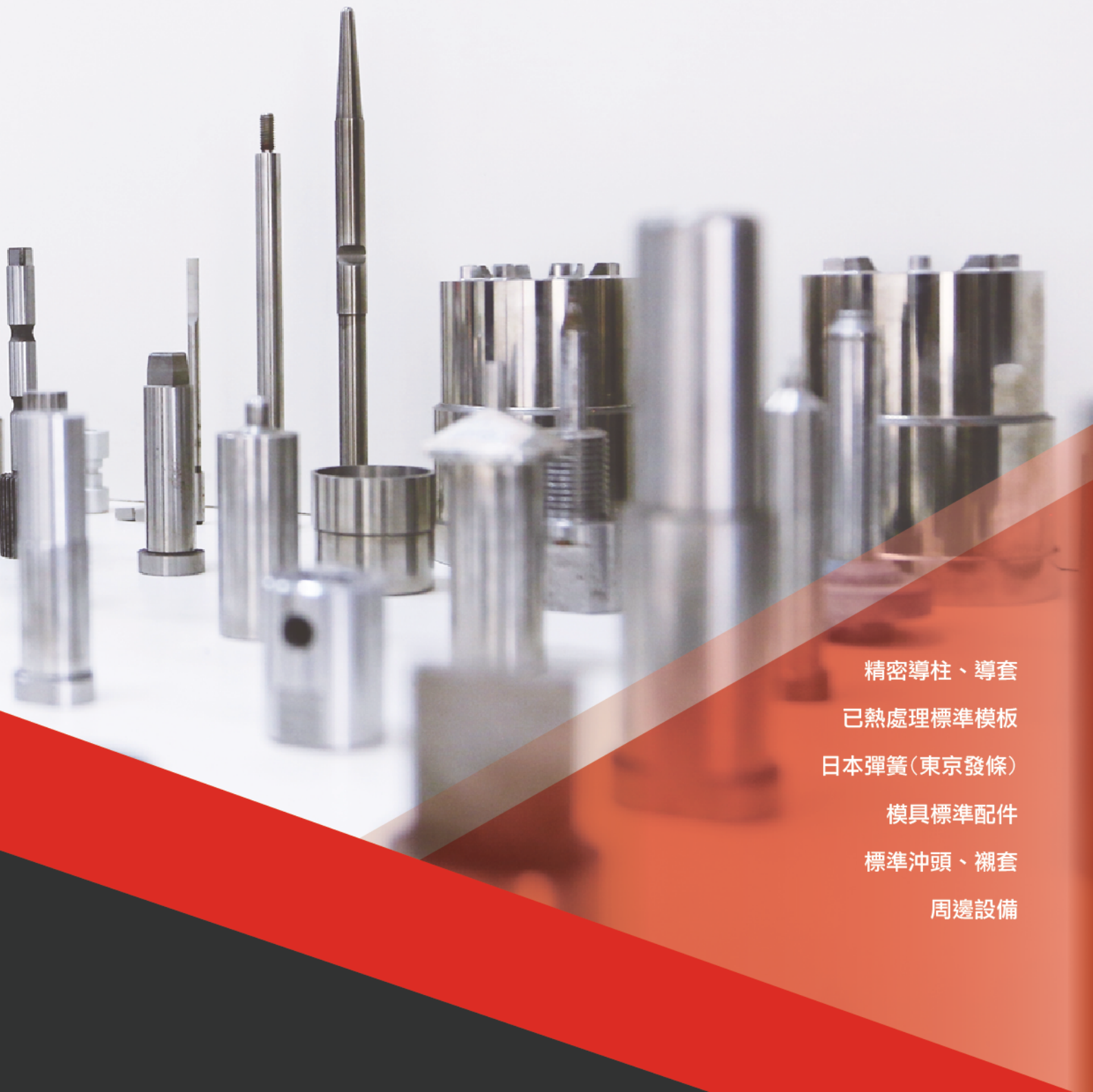

凱泰精工股份有限公司
KAI TAI PRECISION INDUSTRY CO.LTD.

沖壓模具標準零組件

Standard Components of Stamping Die



精密導柱、導套

已熱處理標準模板

日本彈簧(東京發條)

模具標準配件

標準沖頭、襯套

周邊設備



沖壓模具標準零組件

Standard Components of Stamping Die

精密導柱、導套

- 6 GPH . GOH 輔助導柱(日規精密級)
- 7 GBL . GBH 輔助導套(日規精密級)

已熱處理標準模板

- 8 SKD-11 . SK-3 . SS-41 標準規格沖模板(未熱處理)
- 9 D-2 . H-13 . M-2 已熱處理薄板、模塊規格表
- 10 CPM M-4 . CPM T-15 . CPM 10V . G3 G5 粉末高速鋼
已熱處理模板、模塊規格表

日本彈簧(東京發條)

- 12 LR 圓線彈簧(32%壓縮量)
- 13 LR . MR 圓線彈簧(24%壓縮量 . 300mm長)
- 14 LR 1米長彈簧(24%壓縮量)
- 15 AY 圓線彈簧(75%壓縮量)
- 17 AR 圓線彈簧(60%壓縮量)
- 19 AF 圓線彈簧(45%壓縮量)
- 21 AL 圓線彈簧(40%壓縮量)
- 23 AM 圓線彈簧(35%壓縮量)
- 25 AH 圓線彈簧(30%壓縮量)
- 27 AB 圓線彈簧(25%壓縮量)
- 28 NAL . NAM 圓線彈簧(內徑標準型)
- 29 OR 不銹鋼圓線彈簧
- 30 OF 不銹鋼圓線彈簧
- 31 OL 不銹鋼圓線彈簧
- 32 OM 不銹鋼圓線彈簧
- 33 OH 不銹鋼圓線彈簧
- 35 TR 大壓縮量輕荷重彈簧(JIS規格 . 銀色 . 扁線)
- 37 TY 大壓縮量中荷重彈簧(JIS規格 . 紫色 . 扁線)
- 39 TF 輕小荷重彈簧(JIS規格 . 黃色 . 扁線)
- 41 TL . TLR 輕荷重彈簧
- 43 TM 中荷重彈簧(JIS規格 . 紅色 . 扁線)
- 45 TH 重荷重彈簧(JIS規格 . 綠色 . 扁線)
- 47 TB 極重荷重彈簧(JIS規格 . 茶色 . 扁線)
- 49 TJL 輕荷重彈簧(ISO規格 . 綠色 . 扁線)
- 51 TJM 中荷重彈簧(ISO規格 . 藍色 . 扁線)
- 53 TJH 重荷重彈簧(ISO規格 . 紅色 . 扁線)

CONTENTS

54	GS 止付螺絲
55	NSW,NSWS 止付螺絲
56	NSWA . NSWAS 止付螺絲(貫通孔)
57	NSWH . NSWSH 止付螺絲
58	NSWZ . NSWZH 止付螺絲(座付型)
59	PSW . PSSW . PSWP . SCFPK 無頭內六角螺絲
60	AIR-B 真空吸料銷
62	SSS . CCC . BBB . SSH 精密墊片
63	MSSA . MSSB . NP . WPW . NPV 固定銷(精密型、高精密型)
64	MSSE . MSSF 固定銷(不銹鋼、熱處理、精密型)
65	MSSC . MSSD . MSSG . MSSH 固定銷(不銹鋼、固溶化、熱處理)
66	NPBG . NPBG 固定銷(有牙、鋼、不銹鋼)
67	NPBN . NPBNP . NPB 固定銷(有牙、鋼、不銹鋼)
68	NPBS . NPBSE 固定銷(有牙、鋼、不銹鋼)
69	MSB 等高螺絲(ISO規格)
70	CHNN . CHNLL 吊模栓
71	CHPP 吊模塊
72	CHPLL 吊模塊(大頭)
73	GA . GB 優力膠
74	LOC680 厭氧膠
75	KW 華司
76	CSR 等高套筒
77	KTBH 分離式套筒

標準沖頭、襯套

78	MA型 母模襯套
79	MB型 母模襯套
80	A型 標準沖頭
81	B型 標準沖頭
82	A型 引導沖頭

- 83 B型 引導沖頭
- 84 TAP 抽芽沖頭
- 85 JP 子母沖
- 86 GLS 浮昇導料梢

周邊設備

- 87 AT . BT 可調式材料雙面給油機
- 88 SD-401 . 402 沖壓模具微電腦下死點檢出裝置

精密沖壓模座

- 89 KBB . KBBB 鐵製模座
- 90 KCB . KCBB 鐵製模座
- 91 KDB . KDBB 鐵製模座
- 92 KFB . KFBB 鐵製模座
- 93 QDC 快速交換模座
- 94 QDCP 快速換模基本



GPH

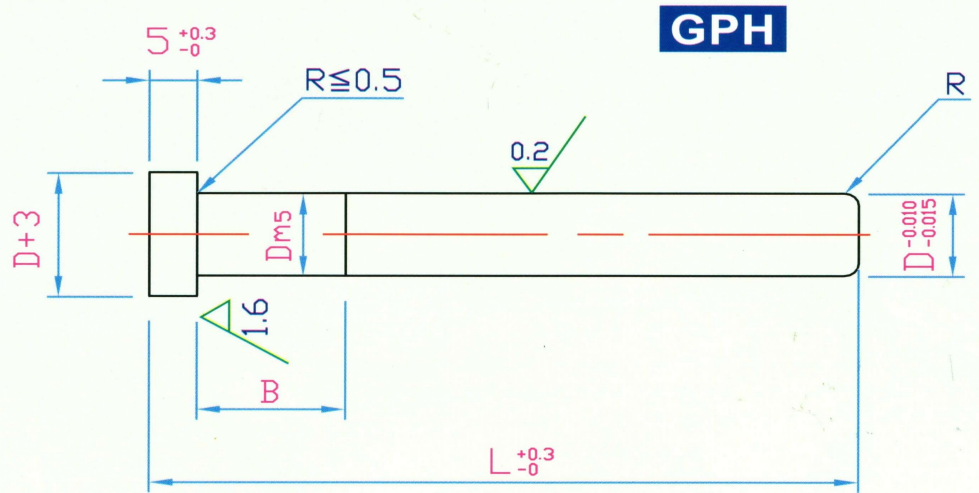

材質：SUJ2 硬度：58HRC~



GOH

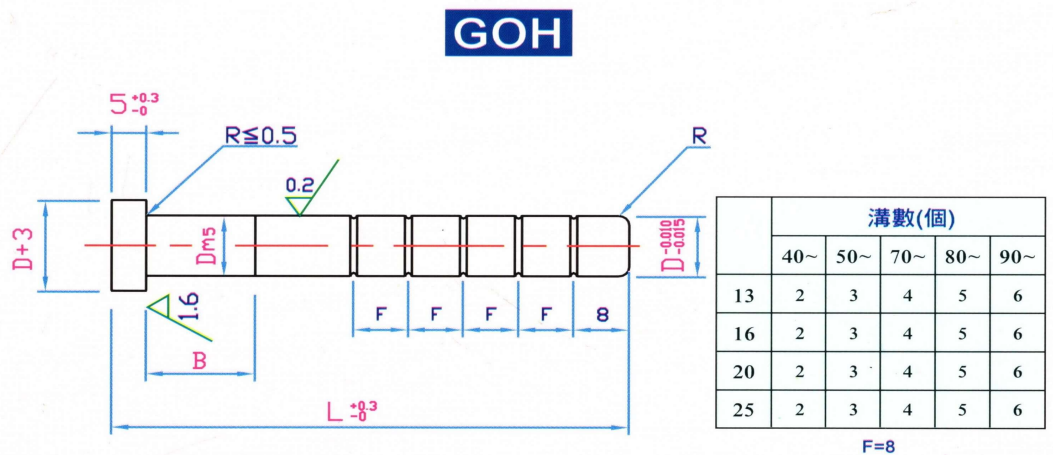

材質：SUJ2 硬度：58HRC~

D _{ms}	R	B	訂購編號		L					
			Type	D						
13	+0.015	16	GPH	13	60	70	80	90		
16	+0.007			16	70	80	90	100		
20	+0.017	25	GOH	20	70	80	90	100	110	
25	+0.008			25				90	100	110

訂購方式：訂購編號 - L 例：GPH 13 - 60



GBL

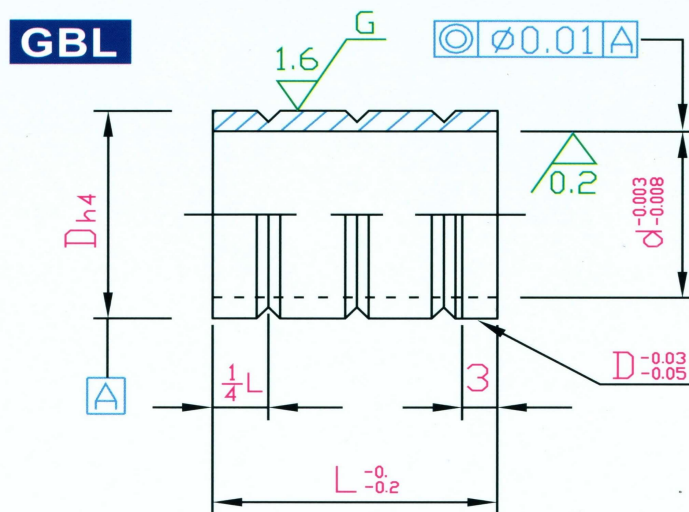

材質：SUJ2 硬度：58HRC~



GBH

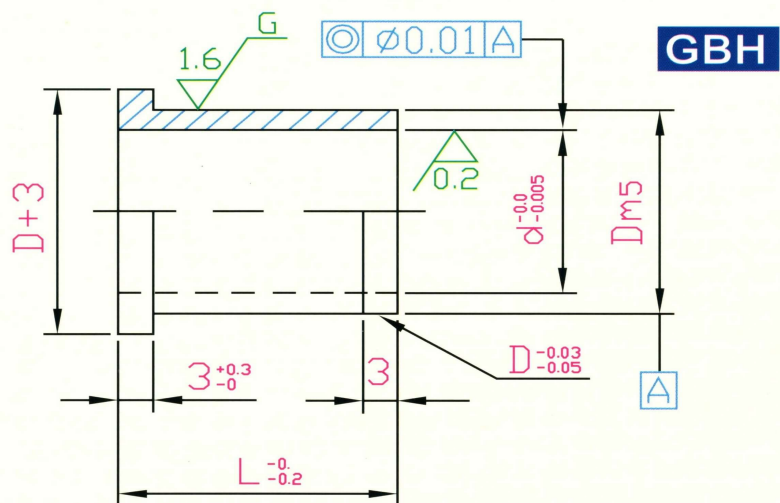

材質：SUJ2 硬度：58HRC~

Dh4	訂購編號		L
	Type	d	
18 +0 -0.005	GBL	13	16 20 22 25
22 +0		16	16 20 22 25 30
25 -0.006		20	20 22 25 30 35
32 +0 -0.007		25	25 30 35

訂購方式：訂購編號 - L 例：GBL 13 - 25

Dm5	訂購編號		L
	Type	d	
18 +0.015 +0.007	GBH	13	16 20 22 25
22 +0.017		16	16 20 22 25 30
25 +0.008		20	16 20 22 25 30 35
32 +0.020 +0.009		25	22 25 30 35

訂購方式：訂購編號 - L 例：GBH 13 - 20

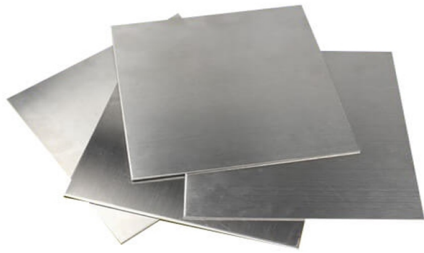

公差

T=+0.3~0.5

W=+0.5~0.8

L=+0.5~0.8

- ◎可接受任何特殊材質、規格、尺寸之訂製
- ◎本產品均未實施熱處理
- ◎長寬高均留熱處理後精修裕量

NO. 長×寬	厚度	SKD-11 (紫牌鋼)					SK-3 (紅牌鋼)					SS-41 (鐵材)							
		12	15	18	25	30	8	12	15	18	25	30	8	11	14	17	20	23	30
1	80x73	●	●	●	●	●	●	●	●	●	●	●	●	●	●	●	●	●	●
2	100x80	●	●	●	●	●	●	●	●	●	●	●	●	●	●	●	●	●	●
3	100x100	●	●	●	●	●	●	●	●	●	●	●	●	●	●	●	●	●	●
4	125x80	●	●	●	●	●	●	●	●	●	●	●	●	●	●	●	●	●	●
5	125x100	●	●	●	●	●	●	●	●	●	●	●	●	●	●	●	●	●	●
6	125x125	●	●	●	●	●	●	●	●	●	●	●	●	●	●	●	●	●	●
7	150x80	●	●	●	●	●	●	●	●	●	●	●	●	●	●	●	●	●	●
8	150x100	●	●	●	●	●	●	●	●	●	●	●	●	●	●	●	●	●	●
9	150x125	●	●	●	●	●	●	●	●	●	●	●	●	●	●	●	●	●	●
10	150x150	●	●	●	●	●	●	●	●	●	●	●	●	●	●	●	●	●	●
11	180x100	●	●	●	●	●	●	●	●	●	●	●	●	●	●	●	●	●	●
12	180x125	●	●	●	●	●	●	●	●	●	●	●	●	●	●	●	●	●	●
13	180x150	●	●	●	●	●	●	●	●	●	●	●	●	●	●	●	●	●	●
14	180x180	●	●	●	●	●	●	●	●	●	●	●	●	●	●	●	●	●	●
15	180x210	●	●	●	●	●	●	●	●	●	●	●	●	●	●	●	●	●	●
16	210x100	●	●	●	●	●	●	●	●	●	●	●	●	●	●	●	●	●	●
17	210x125	●	●	●	●	●	●	●	●	●	●	●	●	●	●	●	●	●	●
18	210x150	●	●	●	●	●	●	●	●	●	●	●	●	●	●	●	●	●	●
19	200x200	●	●	●	●	●	●	●	●	●	●	●	●	●	●	●	●	●	●
20	250x100	●	●	●	●	●	●	●	●	●	●	●	●	●	●	●	●	●	●
21	250x125	●	●	●	●	●	●	●	●	●	●	●	●	●	●	●	●	●	●
22	250x150	●	●	●	●	●	●	●	●	●	●	●	●	●	●	●	●	●	●
23	250x180	●	●	●	●	●	●	●	●	●	●	●	●	●	●	●	●	●	●
24	250x200	●	●	●	●	●	●	●	●	●	●	●	●	●	●	●	●	●	●
25	250x250	●	●	●	●	●	●	●	●	●	●	●	●	●	●	●	●	●	●
26	300x100	●	●	●	●	●	●	●	●	●	●	●	●	●	●	●	●	●	●
27	300x125	●	●	●	●	●	●	●	●	●	●	●	●	●	●	●	●	●	●
28	300x150	●	●	●	●	●	●	●	●	●	●	●	●	●	●	●	●	●	●
29	300x180	●	●	●	●	●	●	●	●	●	●	●	●	●	●	●	●	●	●
30	300x200	●	●	●	●	●	●	●	●	●	●	●	●	●	●	●	●	●	●
31	300x250	●	●	●	●	●	●	●	●	●	●	●	●	●	●	●	●	●	●
32	300x300	●	●	●	●	●	●	●	●	●	●	●	●	●	●	●	●	●	●

訂購方法：材質長×寬×厚×數量

例：SKD-11 300×125×25×2PCS



長寬 厚度	D-2 (SKD-11) HRC 60~62				H-13 (SKD-61) HRC 45~52		M-2 (SKH-51) HRC 62~64				
	60*150	150*150	200*200	200*250	60*150	150*200	60*150	60*250	150*150	150*200	200*200
1								●			
1.5	●				●	●		●			
2	●				●	●		●			
2.5	●				●	●		●			
3	●	●			●	●		●			
3.5	●				●	●		●			
4	●	●			●	●		●	●		
4.5	●				●	●	●				
5	●	●			●	●	●		●		
6	●	●	●		●	●	●		●		
7	●	●			●	●	●		●		
8	●	●	●		●	●	●		●		
9	●	●			●	●	●		●		
10	●	●	●		●	●	●		●		
12		●	●	●		●			●	●	
15		●	●	●		●			●	●	
18		●	●	●		●			●	●	●
20		●	●	●		●			●	●	
22		●	●	●		●			●	●	
25		●	●	●		●			●	●	●
30			●	●		●			●	●	
32			●	●		●			●	●	
35			●								
40			●	●					●		●
45			●	●					●		●
50			●	●					●	●	●
55			●	●					●		
60			●	●					●		

已熱處理系列之各種材質選用參考：

1. 當使用碳化鎢類易於崩烈，或起毛邊時請選用CPM T-15或CPM 10V。
2. 當SKD-61、SKD-11或SKH-51易於磨損時，請選用CPM M-4、CPM T-15、CPM 10V。
3. 當SKD-11或SKH-51易於斷裂時，請選用CPM M-4。
4. 正當選用CPM系列之材料可達10至數十倍以上之壽命。

◎各種特殊型狀、規格、材質歡迎訂製。



		CPM M-4 HRC A=64~66 B=62~64 C=60~62				CPM T-15 HRC 65~67		CPM 10V HRC 60~62		G3、G5 碳化鎢		
長寬 厚度		50*150	60*150	100*150	150*150	50*150	100*150	50*150	100*150	100*105	100*150	150*150
1		●	●							●		
1.5		●	●			●		●		●		
2		●	●			●		●		●		
2.5		●	●							●		
3		●	●			●		●		●		
3.5		●	●							●		
4		●	●			●		●		●		
4.5		●	●							●		
5		●	●			●		●		●	●	
5.5										●		
6		●	●	●		●	●	●	●	●		
6.5										●		
7		●	●			●		●		●		
7.5										●		
8		●	●	●		●	●	●	●	●		
8.5										●		
9		●	●			●		●		●		
10		●	●	●	●	●	●	●	●	●	●	●
11										●		
12				●	●		●		●		●	
13											●	
14											●	
15				●	●		●		●		●	
16				●	●		●		●		●	
18				●	●		●		●		●	
20				●	●		●		●		●	
22				●	●		●		●		●	
25				●	●		●		●		●	●
30				●	●		●		●	●		
32				●	●		●		●			
40				○	○		●		●	●		
45				○	○		●		●	●		
50				○	○		●		●		●	
52										●		
55				○	○		●		●	●		
60				○	○		●		●	●		
65										●		

- * M2 60 × 250之規格，為德國原廠熱處理。
- 本記號所示為備有A、B、C三種硬度之庫存，可選擇。
- * 韌性與耐磨性之比較：◎韌性：M4>10V>M2>D2>T15
◎耐磨性：10V>T15>M4>M2>D2>H13
- * 訂購方式：材質T×W×L×數量
例：CPM M4 (B) 50 × 100 × 150 × 2PCS
例：SKD-61 10 × 150 × 200 × 3PCS

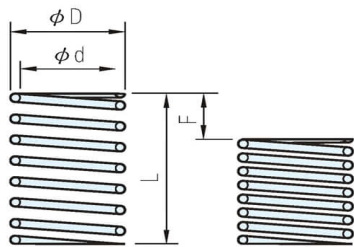

D	d	荷重	直角度	自由長	
+0 -0.5	+0.7 -0.4	±10%	±2°	≤50 ±0.5	≥55 ±1%

材質	顏色
SWOSC-V	本色

品號		D	d	L	定數 N/mm	F=L×16%		F=L×24%		F=L×32%		單價
TYPE	D - L	外徑 mm	內徑 mm	自由長 mm		壓縮量 mm	荷重 N	壓縮量 mm	荷重 N	壓縮量 mm	荷重 N	
LR	03-010	3	2.0	10	2.79	1.6	4.4	2.4	6.7	3.2	8.8	•
	015			15	1.86	2.4		3.6		4.8		•
	020			20	1.40	3.2		4.8		6.4		•
	025			25	1.12	4.0		6.0		8.0		•
LR	04-010	4	2.6	10	4.92	1.6	7.9	2.4	11.8	3.2	15.7	•
	015			15	3.28	2.4		3.6		4.8		•
	020			20	2.46	3.2		4.8		6.4		•
	025			25	1.97	4.0		6.0		8.0		•
	030			30	1.64	4.8		7.2		9.6		•
LR	06-015	6	4.0	15	7.36	2.4	17.7	3.6	26.5	4.8	35.3	•
	020			20	5.52	3.2		4.8		6.4		•
	025			25	4.42	4.0		6.0		8.0		•
	030			30	3.68	4.8		7.2		9.6		•
	035			35	3.15	5.6		8.4		11.2		•
LR	08-015	8	5.4	15	13.08	2.4	31.4	3.6	47.1	4.8	62.8	•
	020			20	9.81	3.2		4.8		6.4		•
	025			25	7.85	4.0		6.0		8.0		•
	030			30	6.54	4.8		7.2		9.6		•
	035			35	5.61	5.6		8.4		11.2		•
	040			40	4.91	6.4		9.6		12.8		•
LR	10-025	10	6.5	25	12.27	4.0	49.0	6.0	73.6	8.0	98.1	•
	030			30	10.22	4.8		7.2		9.6		•
	035			35	8.76	5.6		8.4		11.2		•
	040			40	7.67	6.4		9.6		12.8		•
	045			45	6.81	7.2		10.8		14.4		•
	050			50	6.13	8.0		12.0		16.0		•
LR	12-025	12	8.0	25	17.65	4.0	70.6	6.0	105.9	8.0	141.2	•
	030			30	14.71	4.8		7.2		9.6		•
	035			35	12.61	5.6		8.4		11.2		•
	040			40	11.03	6.4		9.6		12.8		•
	045			45	9.81	7.2		10.8		14.4		•
	050			50	8.83	8.0		12.0		16.0		•
	055			55	8.02	8.8		13.2		17.6		•
	060			60	7.35	9.6		14.4		19.2		•
LR	14-025	14	9.3	25	24.03	4.0	96.1	6.0	144.2	8.0	192.2	•
	030			30	20.03	4.8		7.2		9.6		•
	035			35	17.17	5.6		8.4		11.2		•
	040			40	15.02	6.4		9.6		12.8		•
	045			45	13.35	7.2		10.8		14.4		•
	050			50	12.02	8.0		12.0		16.0		•
	055			55	10.92	8.8		13.2		17.6		•
	060			60	10.01	9.6		14.4		19.2		•
	065			65	9.24	10.4		15.6		20.8		•
	070			70	8.58	11.2		16.8		22.4		•
LR	16-025	16	10.7	25	31.38	4.0	125.5	6.0	188.3	8.0	251.1	•
	030			30	26.15	4.8		7.2		9.6		•
	035			35	22.42	5.6		8.4		11.2		•
	040			40	19.61	6.4		9.6		12.8		•
	045			45	17.44	7.2		10.8		14.4		•
	050			50	15.69	8.0		12.0		16.0		•
055	55	14.27	8.8	13.2	17.6	•						

品 號		D	d	L	定數	F=L×16%		F=L×24%		F=L×32%		單 價
TYPE	D - L	外徑	內徑	自由長	N/mm	壓縮量	荷重	壓縮量	荷重	壓縮量	荷重	
		mm	mm	mm		mm	N	mm	N	mm	N	
LR	16-060	16	10.7	60	13.08	125.5	9.6	188.3	14.4	251.1	19.2	•
	065			65	12.07		10.4		15.6		20.8	•
	070			70	11.21		11.2		16.8		22.4	•
	075			75	10.46		12.0		18.0		24.0	•
	080			80	9.81		12.8		19.2		25.6	•
LR	18-025	18	12.0	25	39.72	158.9	4.0	238.3	6.0	317.7	8.0	•
	030			30	33.10		4.8		7.2		9.6	•
	035			35	28.37		5.6		8.4		11.2	•
	040			40	24.82		6.4		9.6		12.8	•
	045			45	22.06		7.2		10.8		14.4	•
	050			50	19.86		8.0		12.0		16.0	•
	055			55	18.05		8.8		13.2		17.6	•
	060			60	16.55		9.6		14.4		19.2	•
	065			65	15.28		10.4		15.6		20.8	•
	070			70	14.18		11.2		16.8		22.4	•
	075			75	13.24		12.0		18.0		24.0	•
	080			80	12.41		12.8		19.2		25.6	•
	090			90	11.03		14.4		21.6		28.8	•
LR	20-025	20	13.5	25	49.03	196.1	4.0	294.2	6.0	392.3	8.0	•
	030			30	40.86		4.8		7.2		9.6	•
	035			35	35.02		5.6		8.4		11.2	•
	040			40	30.65		6.4		9.6		12.8	•
	045			45	27.24		7.2		10.8		14.4	•
	050			50	24.52		8.0		12.0		16.0	•
	055			55	22.29		8.8		13.2		17.6	•
	060			60	20.43		9.6		14.4		19.2	•
	065			65	18.86		10.4		15.6		20.8	•
	070			70	17.51		11.2		16.8		22.4	•
	075			75	16.34		12.0		18.0		24.0	•
	080			80	15.32		12.8		19.2		25.6	•
	090			90	13.62		14.4		21.6		28.8	•
100	100	12.26	16.0	24.0	32.0	•						
LR	22-025	22	14.7	25	59.33	237.3	4.0	356.0	6.0	474.6	8.0	•
	030			30	49.44		4.8		7.2		9.6	•
	035			35	42.38		5.6		8.4		11.2	•
	040			40	37.08		6.4		9.6		12.8	•
	045			45	32.96		7.2		10.8		14.4	•
	050			50	29.67		8.0		12.0		16.0	•
	055			55	26.97		8.8		13.2		17.6	•
	060			60	24.72		9.6		14.4		19.2	•
	065			65	22.82		10.4		15.6		20.8	•
	070			70	21.19		11.2		16.8		22.4	•
	075			75	19.78		12.0		18.0		24.0	•
	080			80	18.54		12.8		19.2		25.6	•
	090			90	16.48		14.4		21.6		28.8	•
100	100	14.83	16.0	24.0	32.0	•						
LR	25-025	25	17.0	25	76.67	307.0	4.0	460.0	6.0	613.9	8.0	•
	030			30	63.89		4.8		7.2		9.6	•
	035			35	54.76		5.6		8.4		11.2	•
	040			40	47.92		6.4		9.6		12.8	•
	045			45	42.59		7.2		10.8		14.4	•
	050			50	38.33		8.0		12.0		16.0	•
	055			55	34.85		8.8		13.2		17.6	•
	060			60	31.94		9.6		14.4		19.2	•
	065			65	29.49		10.4		15.6		20.8	•
	070			70	27.38		11.2		16.8		22.4	•
	075			75	25.56		12.0		18.0		24.0	•
	080			80	23.96		12.8		19.2		25.6	•
	090			90	21.30		14.4		21.6		28.8	•
100	100	19.17	16.0	24.0	32.0	•						

PS. 備註

- 荷重(N)=定數(N/mm)×壓縮量(mm)
- 耐熱溫度100°C
- 非標準規格彈簧訂購請參考本單元底頁

訂貨： 交期： 天

LR16-060

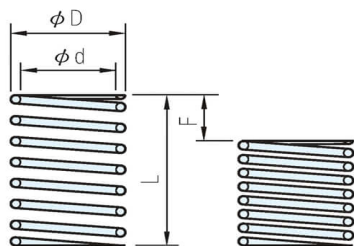

D	d	荷重	直角度	自由長	
+0 -0.5	+0.7 -0.4	±10%	±2°	≤50 ±0.5	≥55 ±1%

TYPE	材質	顏色
LR,MR	SWOSC-V	本色

品 號		D	d	L	定 數	F=L×16%		F=L×20%		F=L×24%		單 價
TYPE	D - L	外 徑	內 徑	自由長	N/mm	壓縮量	荷 重	壓縮量	荷 重	壓縮量	荷 重	
		mm	mm	mm		mm	N	mm	N	mm	N	
MR	06-015	6	3.6	15	12.25	2.4	35.3	3	44.1	3.6	53.0	•
	020			20	9.19	3.2		4		4.8		•
	025			25	7.35	4.0		5		6.0		•
	030			30	6.13	4.8		6		7.2		•
	035			35	5.25	5.6		7		8.4		•
MR	08-015	8	5.0	15	21.81	2.4	68.2	3	78.5	3.6	94.1	•
	020			20	16.35	3.2		4		4.8		•
	025			25	13.08	4.0		5		6.0		•
	030			30	10.90	4.8		6		7.2		•
	035			35	9.35	5.6		7		8.4		•
	040			40	8.18	6.4		8		9.6		•

品 號		D	d	L	Pitch	單 價
TYPE	D - L	外 徑	內 徑	自由長		
		mm	mm	mm		
LR	03-300	3	2.0	300	1.04	•
	04-300	4	2.6		1.5	•
	06-300	6	4.0		2.0	•
	08-300	8	5.4		2.8	•
	10-300	10	6.5		3.5	•
	12-300	12	8.0		4.3	•
	14-300	14	9.3		4.8	•
	16-300	16	10.7		5.5	•
	18-300	18	12.0		5.3	•
	20-300	20	13.5		6.8	•
	22-300	22	14.7		6.7	•
25-300	25	17.0	8.2	•		

品 號		D	d	L	Pitch	單 價
TYPE	D - L	外 徑	內 徑	自由長		
		mm	mm	mm		
MR	06-300	6	3.6	300	1.7	•
	08-300	8	5.0	300	2.8	•

PS. 備註

- 荷重(N)=定數(N/mm)×壓縮量(mm)
- 耐熱溫度100°C
- 1N=0.101972 kgf

訂貨： 交期：

LR16-300



材質	顏色
SWOSC-V	紫

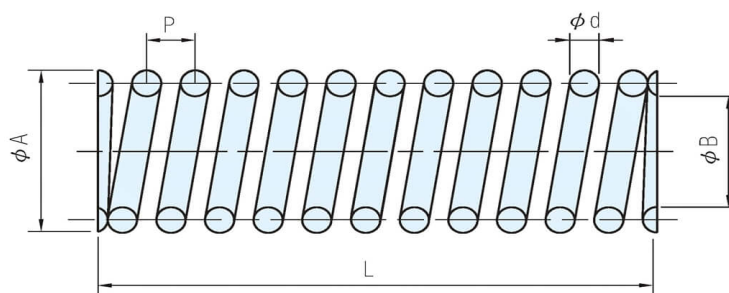

品號	d	A	B	L	P	定數 N/mm	50萬回 (自由長)	最大 壓縮量	適用回 位銷徑	單價
LR20 × 1000	3.5	20	13.0	1000	6.3	2.07	24%	45%	12	•
LR25 × 1000	4.0	25	17.0	1000	7.5	2.04	24%	47%	16	•
LR31 × 1000	5.0	31	21.0	1000	9.5	3.33	24%	47%	20	•
LR38 × 1000	6.0	38	26.0	1000	11.3	4.41	24%	47%	25	•
LR46 × 1000	7.5	46.5	31.5	1000	14.6	8.14	24%	47%	30	•

Wa. 注意

- 最大壓縮量的80%內壓縮使用,彈簧壽命較長
- 切斷使用時,彈簧兩端應磨成平面,並施以適當回火

訂貨： 交期：
LR20 × 1000

PS. 備註

- 裁剪長度的定數 $C = \frac{K \times 1000}{H}$
- C=裁剪長度的定數(N/mm)
- K=長度1000mm之定數(如表列)
- H=裁剪長度
- 1N=0.101972 kgf

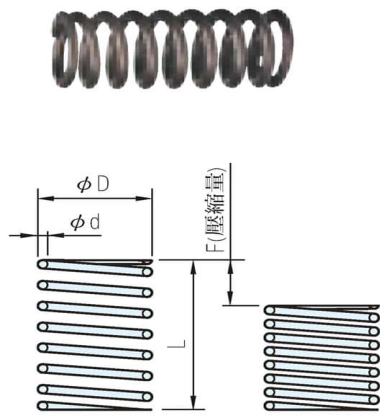

D		L	
≤13	>13	≤50	≥55
+0	+0	±1.5	±2.5
-0.5	-0.8		

材質	顏色
SWP	本色

規格	AY	AR	AF	AL	AT	AM	AH	AB
D				0.5				
2								
3					N/mm 1.5	N/mm 2.0		3.9
4	N/mm 0.1						2.9	4.9
5								
6								
8		N/mm 0.3	N/mm 0.5	N/mm 1.0			N/mm 5.9	N/mm 9.8
10					N/mm 2.0	N/mm 2.9		
12	N/mm 0.2							
13								
14							N/mm 9.8	N/mm 19.6
16								
18								29.4
20		N/mm 0.5	N/mm 1.0	N/mm 2.9	N/mm 3.9	N/mm 4.9	N/mm 14.7	
22								
27								N/mm 29.4
F _{MAX}	F=LX75%	F=LX60%	F=LX45%	F=LX40%	F=LX40%	F=LX35%	F=LX30%	F=LX25%

■ AY:Fmax(容許壓縮量)=LX75%

品號	d	密著長	F	荷重	單價	
TYPE	D-L	mm	max	N/max		
AY	03-05	0.16	1.0	3.75	0.38	
	10	0.20	2.0	7.5	0.75	
	15	0.23	3.6	11.2	1.12	
	20	0.23	3.6	15.0	1.50	
	25	0.25	5.5	18.7	1.87	
	30	0.26	6.5	22.5	2.25	
AY	04-05	0.20	1.1	3.75	0.38	
	10	0.23	1.9	7.5	0.70	
	15	0.23	1.9	11.2	1.10	
	20	0.25	2.7	15.0	1.50	
	25	0.29	5.0	18.7	1.80	
	30	0.29	5.0	22.5	2.20	
AY	35	0.32	7.7	26.2	2.60	
	40	0.32	7.7	30.0	2.90	
	AY	05-10	0.25	1.7	7.5	0.70
		15	0.25	1.7	11.2	1.10
		20	0.30	3.2	15.0	1.50
		25	0.30	3.2	18.7	1.80
30		0.35	6.3	22.5	2.20	
35		0.35	6.3	26.2	2.60	
AY	40	0.38	9.2	30.0	2.90	
	45	0.38	9.2	33.7	3.30	
	50	0.38	9.2	37.5	3.70	
	AY	06-10	0.30	2.1	7.5	0.75
		15	0.32	2.8	11.2	1.10
		20	0.32	2.8	15.0	1.50
25		0.35	4.1	18.7	1.80	
30		0.38	5.6	22.5	2.20	
35		0.38	5.6	26.2	2.60	
AY	40	0.40	7.2	30.0	2.90	
	45	0.40	7.2	33.7	3.30	
	50	0.40	7.2	37.5	3.70	
	55	0.45	12.2	41.2	4.00	
	60	0.45	12.2	45.0	4.40	
	65	0.45	12.2	48.7	4.80	
AY	70	0.45	12.2	52.5	5.10	
	AY	08-10	0.35	2.1	7.5	0.75
		15	0.38	3.0	11.2	1.10

品號	d	密著長	F	荷重	單價	
TYPE	D-L	mm	max	N/max		
AY	08-20	0.40	3.5	15.0	1.50	
	25	0.40	3.5	18.7	1.80	
	30	0.45	5.7	22.5	2.20	
	35	0.45	5.7	26.2	2.60	
	40	0.45	5.7	30.0	2.90	
	45	0.45	5.7	33.7	3.30	
	50	0.50	9.0	37.5	3.70	
	55	0.50	9.0	41.2	4.00	
	60	0.50	9.0	45.0	4.40	
	65	0.50	9.0	48.7	4.80	
AY	70	0.50	9.0	52.5	5.10	
	AY	10-15	0.50	3.0	11.2	2.26
		20	0.55	4.6	15.0	2.90
		25	0.55	4.6	18.7	3.70
		30	0.60	6.6	22.5	4.40
		35	0.60	6.6	26.2	5.10
		40	0.65	9.1	30.0	5.90
		45	0.65	9.1	33.7	6.60
		50	0.65	9.1	37.5	7.40
		55	0.70	12.6	41.2	8.10
60		0.70	12.6	45.0	8.80	
AY	65	0.70	12.6	48.7	9.60	
	70	0.70	12.6	52.5	10.30	
	AY	13-20	0.60	3.9	15.0	2.90
		25	0.65	5.1	18.7	3.70
		30	0.65	5.1	22.5	4.40
		35	0.70	6.7	26.2	5.10
		40	0.75	8.7	30.0	5.90
		45	0.75	8.7	33.7	6.60
		50	0.80	11.6	37.5	7.40
		55	0.80	11.6	41.2	8.10
60		0.80	11.6	45.0	8.80	
65		0.85	15.3	48.7	9.60	
70	0.85	15.3	52.5	10.30		
AY	16-20	0.65	3.6	15.0	2.90	
	25	0.70	4.6	18.7	3.70	
	30	0.75	5.7	22.5	4.40	
35	0.80	7.0	26.2	5.10		

品號	d	密著長	F	荷重	單價
TYPE	D-L	mm	max	N/max	
AY	16-40	0.85	9.0	30.0	5.90
	45	0.85	9.0	33.7	6.60
	50	0.90	11.3	37.5	7.40
	55	0.90	11.3	41.2	8.10
	60	0.90	11.3	45.0	8.80
	65	0.90	11.3	48.7	9.60
	70	0.90	11.3	52.5	10.30

訂貨： 交期： 天
AY03-05

PS. 備註

- 荷重(N)=定數(N/mm)×壓縮量(mm)
- 密著長是參考值,製作時會有少許差異
- AY規格全系列兩端面無研磨
- 耐熱溫度80°C
- 1N=0.101972 kgf

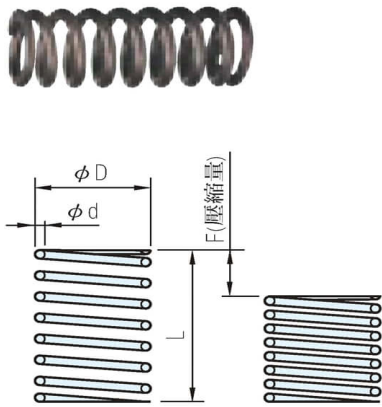

D		L	
≤13	>13	≤50	≥55
+0	+0	±1.5	±2.5
-0.5	-0.8		

材質	顏色
SWP	本色

規格	AY	AR	AF	AL	AT	AM	AH	AB
D								
2				0.5				3.9
3	N/mm 0.1				N/mm 1.5	N/mm 2.0	2.9	4.9
4								
5								
6								
8	N/mm 0.2	N/mm 0.3	N/mm 0.5	N/mm 1.0	N/mm 2.0	N/mm 2.9	N/mm 5.9	N/mm 9.8
10								
12								
13								
14								
16								
18								
20								
22								
27								
FMAX	F=LX75%	F=LX60%	F=LX45%	F=LX40%	F=LX40%	F=LX35%	F=LX30%	F=LX25%

■ AR:Fmax(容許壓縮量)=LX60%

品號	TYPE	D-L	d	密著長 mm	F max	荷重 N/max	單價
AR	03-05	0.23	1.8	3	0.9		
	10	0.25	2.3	6	1.8		
	15	0.30	4.8	9	2.6		
	20	0.30	4.8	12	3.5		
	25	0.32	6.8	15	4.4		
	30	0.32	6.8	18	5.3		
	35	0.35	11.5	21	6.2		
	40	0.35	11.5	24	7.1		
AR	04-05	0.26	1.6	3	0.9		
	10	0.29	2.2	6	1.8		
	15	0.32	3.2	9	2.6		
	20	0.38	6.5	12	3.5		
	25	0.38	6.5	15	4.4		
	30	0.40	8.4	18	5.3		
	35	0.40	8.4	21	6.2		
	40	0.45	15.0	24	7.1		
	45	0.45	15.0	27	7.9		
	50	0.45	15.0	30	8.8		
	55	0.45	15.0	33	9.7		
	60	0.50	23.5	36	10.6		
65	0.50	25.0	39	11.5			
70	0.50	25.0	42	12.4			
AR	05-05	0.30	1.6	3	0.9		
	10	0.35	1.6	6	1.8		
	15	0.35	2.8	9	2.6		
	20	0.40	4.8	12	3.5		
	25	0.45	8.0	15	4.4		
	30	0.45	8.0	18	5.3		
	35	0.50	12.5	21	6.2		
	40	0.50	12.5	24	7.1		
	45	0.55	17.6	27	7.9		
	50	0.55	18.0	30	8.8		
	55	0.55	20.0	33	9.7		
	60	0.55	20.0	36	10.6		
	65	0.55	20.9	39	11.5		
	70	0.55	20.9	42	12.4		
AR	06-05	0.32	1.6	3	0.9		
	10	0.40	3.2	6	1.8		

品號	TYPE	D-L	d	密著長 mm	F max	荷重 N/max	單價
AR	06-15	0.40	3.2	9	2.6		
	20	0.50	7.5	12	3.5		
	25	0.50	7.5	15	4.4		
	30	0.50	7.5	18	5.3		
	35	0.55	11.5	21	6.2		
	40	0.55	11.5	24	7.1		
	45	0.60	17.4	27	7.9		
	50	0.60	17.4	30	8.8		
	55	0.60	17.4	33	9.7		
	60	0.60	17.4	36	10.6		
AR	08-10	0.45	2.7	6	1.8		
	15	0.50	4.0	9	2.6		
	20	0.50	4.0	12	3.5		
	25	0.55	5.8	15	4.4		
	30	0.60	8.4	18	5.3		
	35	0.60	8.4	21	6.2		
	40	0.60	8.4	24	7.1		
	45	0.70	16.0	27	7.9		
	50	0.70	16.0	30	8.8		
	55	0.70	16.0	33	9.7		
AR	10-10	0.55	3.6	6	1.8		
	15	0.60	4.8	9	2.6		
	20	0.65	6.5	12	3.5		
	25	0.65	6.5	15	4.4		
	30	0.70	8.8	18	5.3		
	35	0.70	8.8	21	6.2		
	40	0.70	8.8	24	7.1		
	45	0.80	16.0	27	7.9		
	50	0.80	16.0	30	8.8		
	55	0.80	16.0	33	9.7		
AR	60	0.85	21.0	36	10.6		

品號	TYPE	D-L	d	密著長 mm	F max	荷重 N/max	單價	
								D-L
AR	10-65	0.85	21.0	39	11.5			
	70	0.85	21.0	42	12.4			
	80	0.90	28.8	48	14.1			
AR	12-10	0.60	3.6	6	1.8			
	15	0.65	4.6	9	2.6			
	20	0.65	4.6	12	3.5			
	25	0.70	6.0	15	4.4			
	30	0.70	6.0	18	5.3			
	35	0.70	6.0	21	6.2			
	40	0.80	10.4	24	7.1			
	45	0.80	10.4	27	7.9			
	50	0.90	17.1	30	8.8			
	55	0.90	17.1	33	9.7			
AR	60	0.90	17.1	36	10.6			
	65	0.90	17.1	39	11.5			
	70	0.90	17.1	42	12.4			
	80	1.00	28.0	48	14.1			
	AR	13-10	0.60	3.2	6	1.8		
		15	0.70	4.9	9	2.6		
		20	0.70	4.9	12	3.5		
		25	0.80	8.4	15	4.4		
		30	0.80	8.4	18	5.3		
		35	0.80	8.4	21	6.2		
40		0.90	13.5	24	7.1			
45		0.90	13.5	27	7.9			
50		0.90	13.5	30	8.8			
55		0.90	13.5	33	9.7			
AR	60	1.00	22.0	36	10.6			
	65	1.00	22.0	39	11.5			
	70	1.00	22.0	42	12.4			
	80	1.00	22.0	48	14.1			
	90	1.00	22.0	54	15.9			
	AR	14-15	0.70	4.6	9	2.6		
		20	0.75	5.6	12	3.5		
		25	0.80	7.2	15	4.4		
		30	0.80	7.2	18	5.3		
		35	0.80	7.2	21	6.2		
40		0.90	11.3	24	7.1			

品號		d	密著長 mm	F max	荷重 N/max	單價		
TYPE	D-L							
AR	14-45	0.90	11.3	27	7.9	•		
	50	0.90	11.3	30	8.8			
	55	1.00	18.0	33	9.7			
	60	1.00	18.0	36	10.6			
	65	1.00	18.0	39	11.5			
	70	1.00	18.0	42	12.4			
	80	1.10	28.6	48	14.1			
	90	1.10	28.6	54	15.9			
AR	16-15	0.75	4.5	9	2.6	•		
	20	0.80	5.6	12	3.5			
	25	0.90	8.0	15	4.4			
	30	0.90	8.0	18	5.3			
	35	0.90	8.0	21	6.2			
	40	1.00	13.0	24	7.1			
	45	1.00	13.0	27	7.9			
	50	1.00	13.0	30	8.8			
	55	1.00	13.0	33	9.7			
	60	1.10	20.0	36	10.6			
	65	1.10	20.0	39	11.5			
AR	70	1.10	20.0	42	12.4	•		
	80	1.10	20.0	48	14.1			
	90	1.20	28.8	54	15.9			
	18-20	1.00	7.0	12	5.8			
	25	1.00	7.0	15	7.4			
	30	1.10	9.9	18	8.8			
	35	1.10	9.9	21	10.3			
	40	1.20	14.4	24	11.8			
	45	1.20	14.4	27	13.2			
	50	1.20	14.4	30	14.7			
AR	55	1.30	19.5	33	16.2	•		
	60	1.30	19.5	36	17.7			
	65	1.30	19.5	39	19.1			
	70	1.30	19.5	42	20.6			
	80	1.40	27.3	48	23.5			
	20-20	1.00	6.0	12	5.8			
	25	1.10	8.3	15	7.4			
	30	1.10	8.3	18	8.8			
	35	1.20	10.8	21	10.3			
	40	1.20	10.8	24	11.8			
AR	45	1.20	10.8	27	13.2	•		
	50	1.30	15.0	30	14.7			
	55	1.30	15.0	33	16.2			
	60	1.30	15.0	36	17.7			
	65	1.30	15.0	39	19.1			
	70	1.40	21.0	42	20.6			
	80	1.40	21.0	48	23.5			
	AR	22-20	1.10	6.9	12		5.9	•
		25	1.20	9.0	15		7.4	
		30	1.20	9.0	18		8.8	
35		1.30	12.4	21	10.3			
40		1.30	12.4	24	11.8			
45		1.30	12.4	27	13.2			
50		1.40	16.1	30	14.7			
55		1.40	16.1	33	16.2			
60		1.40	16.1	36	17.7			
65		1.50	22.5	39	19.1			
AR	70	1.50	22.5	42	20.6	•		
	80	1.50	22.5	48	23.5			

品號		d	密著長 mm	F max	荷重 N/max	單價
TYPE	D-L					
AR	27-30	1.30	8.5	18	8.8	•
	35	1.40	10.5	21	10.3	
	40	1.40	10.5	24	11.8	
	45	1.40	10.5	27	13.2	
	50	1.60	17.6	30	14.7	
	55	1.60	17.6	33	16.2	
	60	1.60	17.6	36	17.7	
	65	1.70	22.1	39	19.1	
	70	1.70	22.1	42	20.6	
	80	1.70	22.1	48	23.5	

訂貨： 交期：

AR14-45

PS: 備註

- 荷重(N)=定數(N/mm)×壓縮量(mm)
- 密著長是參考值,製作時會有少許差異
- AR規格全系列兩端面無研磨
- 耐熱溫度80°C
- 1N=0.101972 kaf

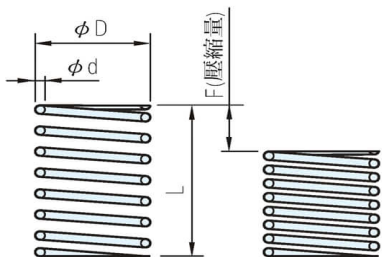

D		L	
≤13	>13	≤50	≥55
+0	+0	±1.5	±2.5
-0.5	-0.8		

材質	顏色
SWP	本色

規格 D	AY	AR	AF	AL	AT	AM	AH	AB				
2				0.5								
3	N/mm 0.1				N/mm 1.5	N/mm 2.0	2.9	3.9				
4								4.9				
5					N/mm 0.2	N/mm 0.3	N/mm 0.5	N/mm 1.0	N/mm 2.0	N/mm 2.9	N/mm 5.9	
6											N/mm 9.8	
8	N/mm 0.5	N/mm 1.0	N/mm 2.9	N/mm 3.9							N/mm 4.9	N/mm 9.8
10												N/mm 19.6
12							29.4					
13												
14												
16												
18												
20		N/mm 0.5	N/mm 1.0	N/mm 2.9	N/mm 3.9	N/mm 4.9	N/mm 14.7					
22												
27								N/mm 29.4				
F _{MAX}	F=LX75%	F=LX60%	F=LX45%	F=LX40%	F=LX40%	F=LX35%	F=LX30%	F=LX25%				

AF:Fmax(容許壓縮量)=LX45%

品號 TYPE	D-L	d	密著長 mm	F max	荷重 N/max	單價
	10*	0.32	5.0	4.5	2.2	
	15*	0.32	5.0	6.7	3.2	
	20*	0.35	7.0	9.0	4.4	
	25*	0.35	7.0	11.2	5.5	
	30	0.40	13.2	13.5	6.6	
	35	0.40	13.2	15.7	7.6	
	40	0.40	13.2	18.0	8.8	
AF	04-05*	0.32	2.3	2.25	1.1	
	10*	0.35	3.1	4.5	2.2	
	15*	0.40	5.6	6.7	3.2	
	20*	0.40	5.6	9.0	4.4	
	25*	0.45	9.9	11.2	5.5	
	30*	0.45	9.9	13.5	6.6	
	35	0.50	16.5	15.7	7.6	
	40	0.50	16.5	18.0	8.8	
	45	0.50	16.5	20.0	9.8	
	50	0.50	16.5	22.5	10.8	
	55	0.50	16.5	24.7	12.1	
	60	0.50	16.5	27.0	12.7	
	65*	0.55	26.4	29.2	14.3	
	70*	0.55	26.4	31.5	15.4	
AF	05-05*	0.35	2.0	2.25	1.1	
	10*	0.38	2.8	4.5	2.2	
	15*	0.40	3.4	6.7	3.2	
	20*	0.45	5.4	9.0	4.4	
	25*	0.50	8.5	11.2	5.5	
	30	0.55	13.2	13.5	6.6	
	35	0.55	13.2	15.7	7.6	
	40	0.55	20.4	18.0	8.8	
	45	0.60	20.4	20.0	9.8	
	50	0.60	20.4	22.5	10.8	
	55	0.60	20.4	24.7	12.1	
	60	0.60	20.4	27.0	12.7	
	65	0.60	20.4	29.2	14.3	
	70	0.60	20.4	31.5	15.4	
AF	06-05*	0.40	2.3	2.25	1.1	
	10	0.50	5.0	4.5	2.2	

品號 TYPE	D-L	d	密著長 mm	F max	荷重 N/max	單價
	20	0.55	8.0	9.0	4.4	
	25	0.60	12.0	11.2	5.5	
	30	0.65	16.0	13.5	6.6	
	35	0.65	17.0	15.7	7.6	
	40	0.65	17.0	18.0	8.8	
	45	0.65	17.0	20.0	9.8	
	50	0.70	25.2	22.5	10.8	
	55	0.70	25.2	24.7	12.1	
	60	0.70	25.2	27.0	12.7	
	65	0.70	25.2	29.2	14.3	
	70	0.70	25.2	31.5	14.7	
	80	0.70	25.2	36.0	17.7	
AF	08-10	0.60	5.0	4.5	2.2	
	15	0.65	7.5	6.7	3.2	
	20	0.70	10.8	9.0	4.4	
	25	0.70	10.8	11.2	5.5	
	30	0.75	14.5	13.5	6.6	
	35	0.75	14.5	15.7	7.6	
	40	0.80	20.0	18.0	8.8	
	45	0.80	20.0	20.0	9.8	
	50	0.80	20.0	22.5	10.8	
	55	0.80	20.0	24.7	12.1	
	60	0.85	27.6	27.0	12.7	
	65	0.85	27.6	29.2	14.3	
	70	0.85	27.6	31.5	14.7	
	80	0.85	28.1	36.0	17.7	
AF	10-10	0.65	5.0	4.5	2.2	
	15	0.65	5.0	6.7	3.2	
	20	0.80	10.4	9.0	4.4	
	25	0.80	10.4	11.2	5.5	
	30	0.85	14.0	13.5	6.6	
	35	0.85	14.0	15.7	7.6	
	40	0.90	17.5	18.0	8.8	
	45	0.90	17.5	20.0	9.8	
	50	0.90	17.5	22.5	10.8	
	55	0.90	17.5	24.7	12.1	
	60	1.00	31.0	27.0	12.7	

品號 TYPE	D-L	d	密著長 mm	F max	荷重 N/max	單價
	70	1.00	31.0	31.5	14.7	
	80	1.00	31.0	36.0	17.7	
AF	12-10	0.70	4.6	4.5	2.3	
	15	0.70	4.6	6.7	3.2	
	20	0.80	7.2	9.0	4.4	
	25	0.80	7.2	11.2	5.5	
	30	0.90	11.3	13.5	6.6	
	35	0.90	11.3	15.7	7.6	
	40	0.90	11.3	18.0	8.8	
	45	0.90	11.3	20.0	9.8	
	50	1.00	18.0	22.5	10.8	
	55	1.00	18.0	24.7	12.1	
	60	1.00	18.0	27.0	12.7	
	65	1.00	18.0	29.2	14.3	
	70	1.10	28.1	31.5	14.7	
	80	1.10	27.5	36.0	17.7	
AF	13-10	0.75	4.9	4.5	2.3	
	15	0.80	6.0	6.7	3.2	
	20	0.80	6.0	9.0	4.4	
	25	0.85	7.2	11.2	5.5	
	30	1.00	15.0	13.5	6.6	
	35	1.00	15.0	15.7	7.6	
	40	1.00	15.0	18.0	8.8	
	45	1.00	15.0	20.0	9.8	
	50	1.00	15.0	22.5	10.8	
	55	1.10	22.0	24.7	12.1	
	60	1.10	22.0	27.0	12.7	
	65	1.10	22.0	29.2	14.3	
	70	1.10	22.0	31.5	14.7	
	80	1.10	22.0	36.0	17.7	
	90	1.20	33.6	40.5	19.9	
AF	14-15	0.80	5.2	6.7	3.2	
	20	0.90	7.9	9.0	4.4	
	25	0.90	7.9	11.2	5.5	
	30	1.00	12.0	13.5	6.6	
	35	1.00	12.0	15.7	7.6	
	40	1.00	12.0	18.0	8.8	

品號		d	密著長 mm	F max	荷重 N/max	單價
TYPE	D-L					
AF	14-45	1.00	12.0	20.0	9.8	•
	50	1.10	18.2	22.5	10.8	
	55	1.10	18.2	24.7	12.1	
	60	1.10	18.2	27.0	12.7	
	65	1.20	27.6	29.2	14.3	
	70	1.20	27.6	31.5	14.7	
	80	1.20	27.6	36.0	17.7	
	90	1.30	39.7	40.5	19.9	
AF	16-15	0.90	6.3	6.7	3.2	•
	20	1.00	8.7	9.0	4.4	
	25	1.00	8.7	11.2	5.5	
	30	1.10	12.8	13.5	6.6	
	35	1.10	12.8	15.7	7.6	
	40	1.20	18.6	18.0	8.8	
	45	1.20	18.6	20.0	9.8	
	50	1.20	18.6	22.5	10.8	
	55	1.20	18.6	24.7	12.1	
	60	1.30	26.8	27.0	12.7	
	65	1.30	26.8	29.2	14.3	
	70	1.30	26.8	31.5	14.7	
80	1.40	36.0	36.0	17.7		
90	1.40	36.4	40.5	19.9		
AF	18-20	1.20	9.0	9.0	8.8	•
	25	1.30	12.4	11.2	10.8	
	30	1.30	12.4	13.5	12.7	
	35	1.40	16.1	15.7	14.7	
	40	1.50	21.0	18.0	17.7	
	45	1.50	21.0	20.0	19.9	
	50	1.50	21.0	22.5	22.1	
	55	1.60	28.8	24.7	24.3	
	60	1.60	28.8	27.0	26.5	
	65	1.60	28.8	29.2	28.7	
70	1.70	37.4	31.5	30.9		
80	1.70	37.4	36.0	35.3		
AF	20-20	1.20	7.2	9.0	8.8	•
	25	1.30	9.8	11.2	10.8	
	30	1.40	12.6	13.5	12.7	
	35	1.40	12.6	15.7	14.7	
	40	1.50	16.5	18.0	17.7	
	45	1.50	16.5	20.0	19.9	
	50	1.60	21.6	22.5	22.1	
	55	1.60	21.6	24.7	24.3	
	60	1.60	21.6	27.0	26.5	
	65	1.70	28.1	29.2	28.7	
70	1.70	28.1	31.5	30.9		
80	1.70	28.1	36.0	35.3		
AF	22-20	1.30	7.8	9.0	8.8	•
	25	1.40	10.5	11.2	11.0	
	30	1.40	10.5	13.5	13.2	
	35	1.50	13.5	15.7	15.4	
	40	1.50	13.5	18.0	17.7	
	45	1.70	22.1	20.2	19.8	
	50	1.70	22.1	22.5	22.1	
	55	1.70	22.1	24.7	24.2	
	60	1.80	28.8	27.0	26.5	
	65	1.80	28.8	29.2	28.6	
70	1.80	28.8	31.5	30.9		
80	1.80	28.8	36.0	35.3		

品號		d	密著長 mm	F max	荷重 N/max	單價
TYPE	D-L					
AF	27-30	1.70	14.1	13.5	13.2	•
	35	1.70	14.1	15.7	15.4	
	40	1.70	14.1	18.0	17.7	
	45	1.90	21.4	20.2	19.8	
	50	1.90	21.4	22.5	22.1	
	55	2.00	26.0	24.7	24.2	
	60	2.00	26.0	27.0	26.5	
	65	2.00	26.0	29.2	28.6	
	70	2.00	26.0	31.5	30.9	
80	2.00	26.0	36.0	35.3		

訂貨： 交期：

AF14-45

PS. 備註

- 荷重(N)=定數(N/mm)×壓縮量(mm)
- 密著長是參考值,製作時會有少許差異
- ★記號兩端面無研磨
- 耐熱溫度80°C
- 1N=0.101972 kgf

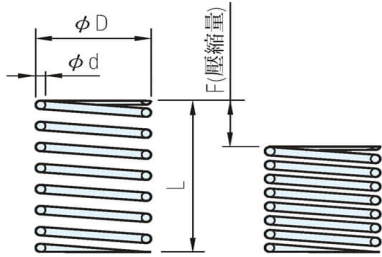

D		L	
≤ 13	> 13	≤ 50	≥ 55
+0	+0	± 1.5	± 2.5
-0.5	-0.8		

材質	顏色
SWP	本色

規格	AY	AR	AF	AL	AT	AM	AH	AB
D								
2				0.5				
3	N/mm 0.1				N/mm 1.5	N/mm 2.0	2.9	3.9
4								4.9
5								
6								
8		N/mm 0.3	N/mm 0.5	N/mm 1.0			N/mm 5.9	N/mm 9.8
10					N/mm 2.0	N/mm 2.9		
12	N/mm 0.2						N/mm 9.8	N/mm 9.8
13								
14								
16								
18								29.4
20		N/mm 0.5	N/mm 1.0	N/mm 2.9	N/mm 3.9	N/mm 4.9	N/mm 14.7	
22								N/mm 29.4
FMAX	F=LX75%	F=LX60%	F=LX45%	F=LX40%	F=LX40%	F=LX35%	F=LX30%	F=LX25%

■ AL:Fmax(容許壓縮量)=LX40%

品號	TYPE	D-L	d	密著長 mm	F max	荷重 N/max	單價
		10*	0.26	5.2	4	2.0	
		15*	0.26	5.2	6	2.9	
		20*	0.29	9.0	8	3.9	
		25*	0.29	9.0	10	4.9	
		30*	0.30	10.8	12	5.9	
		03-05*	0.30	2.1	2	2.0	
		10*	0.35	3.9	4	3.9	
		15*	0.40	6.5	6	5.9	
		20*	0.40	6.5	8	7.8	
		25*	0.45	13.0	10	9.8	
		30*	0.45	13.0	12	11.8	
		35*	0.45	13.0	14	13.7	
		40*	0.50	21.0	16	15.7	
		04-05*	0.35	2.1	2	2.0	
		10*	0.45	5.0	4	3.9	
		15*	0.45	5.0	6	5.9	
		20	0.50	9.0	8	7.8	
		25	0.50	9.0	10	9.8	
		30	0.55	13.9	12	11.8	
		35	0.55	13.9	14	13.7	
		40	0.60	21.6	16	15.7	
		45	0.60	21.6	18	17.7	
		50	0.60	21.6	20	19.6	
		55	0.60	21.6	22	21.6	
		60	0.65	33.0	24	23.5	
		05-05*	0.40	2.3	2	2.0	
		10*	0.45	3.4	4	3.9	
		15*	0.50	5.0	6	5.9	
		20	0.55	7.7	8	7.8	
		25	0.60	10.8	10	9.8	
		30	0.60	10.8	12	11.8	
		35	0.65	15.6	14	13.7	
		40	0.65	15.6	16	15.7	
		45	0.70	20.0	18	17.7	
		50	0.70	20.0	20	19.6	
		55	0.70	23.1	22	21.6	
		60	0.75	33.0	24	23.5	

品號	TYPE	D-L	d	密著長 mm	F max	荷重 N/max	單價
		70	0.75	32.3	28	27.5	
		06-05*	0.45	2.5	2	2.0	
		10	0.55	4.7	4	3.9	
		15	0.55	4.7	6	5.9	
		20	0.65	9.0	8	7.8	
		25	0.65	9.0	10	9.8	
		30	0.70	13.7	12	11.8	
		35	0.70	13.7	14	13.7	
		40	0.70	13.7	16	15.7	
		45	0.75	18.9	18	17.7	
		50	0.75	18.9	20	19.6	
		55	0.75	18.9	22	21.6	
		60	0.80	26.4	24	23.5	
		65	0.80	26.4	26	25.5	
		70	0.85	30.6	28	27.5	
		80	0.85	34.9	32	31.4	
		08-10	0.65	4.7	4	3.9	
		15	0.75	8.5	6	5.9	
		20	0.75	8.5	8	7.8	
		25	0.75	8.5	10	9.8	
		30	0.80	11.2	12	11.8	
		35	0.80	11.2	14	13.7	
		40	0.80	11.2	16	15.7	
		45	0.85	15.3	18	17.7	
		50	0.85	15.3	20	19.6	
		55	0.85	15.3	22	21.6	
		60	0.90	19.4	24	23.5	
		65	0.90	19.4	26	25.5	
		70	1.00	31.0	28	27.5	
		80	1.00	31.0	32	31.4	
		10-10	0.75	5.3	4	3.9	
		15	0.80	6.4	6	5.9	
		20	0.80	6.4	8	7.8	
		25	0.90	10.8	10	9.8	
		30	0.90	10.8	12	11.8	
		35	0.90	10.8	14	13.7	
		40	0.90	10.8	16	15.7	

品號	TYPE	D-L	d	密著長 mm	F max	荷重 N/max	單價
		50	1.00	17.0	20	19.6	
		55	1.00	17.0	22	21.6	
		60	1.00	17.0	24	23.5	
		65	1.10	24.0	26	25.5	
		70	1.10	24.0	28	27.5	
		80	1.10	24.2	32	31.4	
		12-10	0.80	4.8	4	4.0	
		15	0.90	7.2	6	5.9	
		20	0.90	7.2	8	7.8	
		25	0.90	7.2	10	9.8	
		30	1.00	10.5	12	11.8	
		35	1.00	10.5	14	13.7	
		40	1.00	10.5	16	15.7	
		45	1.10	15.4	18	17.7	
		50	1.10	15.4	20	19.6	
		55	1.10	15.4	22	21.6	
		60	1.20	22.8	24	23.5	
		65	1.20	22.8	26	25.5	
		70	1.20	22.8	28	27.5	
		80	1.30	34.5	32	31.4	
		13-10	0.85	5.1	4	4.0	
		15	0.90	6.3	6	5.9	
		20	1.00	8.7	8	7.8	
		25	1.00	8.7	10	9.8	
		30	1.10	13.2	12	11.8	
		35	1.10	13.2	14	13.7	
		40	1.10	13.2	16	15.7	
		45	1.10	13.2	18	17.7	
		50	1.10	13.2	20	19.6	
		55	1.10	13.2	22	21.6	
		60	1.10	13.2	24	23.5	
		65	1.20	18.6	26	25.5	
		70	1.20	18.6	28	27.5	
		80	1.40	37.8	32	31.4	
		90	1.40	37.8	36	35.3	
		14-15	1.00	7.5	6	5.9	
		20	1.00	7.5	8	7.8	

品號		d	密著長	F	荷重	單價	
TYPE	D-L	mm	max	N/max			
AL	14-25	1.00	7.5	10	9.8	•	
	30	1.10	11.0	12	11.8		
	35	1.10	11.0	14	13.7		
	40	1.10	11.0	16	15.7		
	45	1.20	15.6	18	17.7		
	50	1.20	15.6	20	19.6		
	55	1.20	15.6	22	21.6		
	60	1.20	15.6	24	23.5		
	65	1.30	22.1	26	25.5		
	70	1.30	22.1	28	27.5		
AL	80	1.30	22.1	32	31.4	•	
	90	1.50	43.5	36	35.3		
	16-15	1.10	8.2	6	5.9		•
	20	1.10	8.2	8	7.8		
	25	1.20	10.0	10	9.8		
	30	1.20	10.0	12	11.8		
	35	1.20	10.0	14	13.7		
	40	1.20	10.0	16	15.7		
	45	1.40	21.0	18	17.7		
	50	1.40	21.0	20	19.6		
55	1.40	21.0	22	21.6			
60	1.40	21.0	24	23.5			
AL	65	1.50	29.7	26	25.5	•	
	70	1.50	29.7	28	27.5		
	80	1.50	29.7	32	31.4		
	90	1.60	40.0	36	35.3		
	18-20	1.50	10.0	8	23.5		•
	25	1.60	12.0	10	29.4		
	30	1.60	12.0	12	35.3		
	35	1.70	16.2	14	41.2		
	40	1.70	16.2	16	47.1		
	45	1.80	19.8	18	53.0		
50	1.80	19.8	20	58.8			
55	1.80	19.8	22	64.7			
60	1.80	19.8	24	70.6			
65	2.00	32.0	26	76.5			
AL	70	2.00	32.0	28	82.4	•	
	80	2.00	32.0	32	94.1		
	90	2.20	43.0	36	105.9		
	100	2.20	43.0	40	117.7		
	20-20	1.60	10.4	8	23.5		•
	25	1.60	10.4	10	29.4		
	30	1.70	12.8	12	35.3		
	35	1.70	12.8	14	41.2		
	40	1.80	15.8	16	47.1		
	45	1.80	15.8	18	53.0		
50	1.80	15.8	20	58.8			
55	1.80	15.8	22	64.7			
60	2.00	24.0	24	70.6			
65	2.00	24.0	26	76.5			
AL	70	2.00	24.0	28	82.4	•	
	80	2.20	37.4	32	94.1		
	90	2.20	37.4	36	105.9		
	100	2.20	37.4	40	117.7		
	22-20	1.70	10.8	8	23.5		•
	25	1.80	13.3	10	29.4		
	30	1.80	13.3	12	35.3		
	35	1.80	13.3	14	41.2		

品號		d	密著長	F	荷重	單價
TYPE	D-L	mm	max	N/max		
AL	22-40	2.00	20.0	16	47.1	•
	45	2.00	20.0	18	53.0	
	50	2.00	20.0	20	58.8	
	55	2.00	20.0	22	64.7	
	60	2.20	28.6	24	70.6	
	65	2.20	28.6	26	76.5	
	70	2.20	28.6	28	82.4	
	80	2.20	28.6	32	94.1	
	90	2.30	34.5	36	105.9	
	100	2.30	34.5	40	117.7	
AL	27-30	2.10	14.0	12	35.3	•
	35	2.10	14.0	14	41.2	
	40	2.30	19.0	16	47.1	
	45	2.30	19.0	18	53.0	
	50	2.30	19.0	20	58.8	
	55	2.30	19.0	22	64.7	
	60	2.50	28.0	24	70.6	
	65	2.50	28.0	26	76.5	
	70	2.60	34.5	28	82.4	
	80	2.60	34.5	32	94.1	
AL	90	2.80	46.7	36	105.9	•
	100	2.80	46.7	40	117.7	

訂貨： 交期：

AL14-25

PS. 備註

- 荷重(N)=定數(N/mm)×壓縮量(mm)
- 密著長是參考值,製作時會有少許差異
- ★記號兩端面無研磨
- 耐熱溫度80°C
- 1N=0.101972 kgf

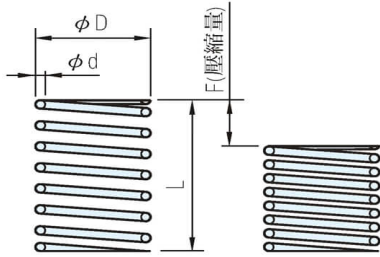

D		L	
≤13	>13	≤50	≥55
+0	+0	±1.5	±2.5
-0.5	-0.8		

材質	顏色
SWP	本色

規格	AY	AR	AF	AL	AT	AM	AH	AB
D				0.5				
2								3.9
3	N/mm 0.1				N/mm 1.5	N/mm 2.0	2.9	4.9
4								
5								
6	N/mm 0.2	N/mm 0.3	N/mm 0.5	N/mm 1.0	N/mm 2.0	N/mm 2.9	N/mm 5.9	N/mm 9.8
8								
10								
12								N/mm 19.6
13								29.4
14								
16								
18								
20		N/mm 0.5	N/mm 1.0	N/mm 2.9	N/mm 3.9	N/mm 4.9	N/mm 14.7	
22								N/mm 29.4
27								
F _{MAX}	F=LX75%	F=LX60%	F=LX45%	F=LX40%	F=LX40%	F=LX35%	F=LX30%	F=LX25%

■ AM:Fmax(容許壓縮量)=LX35%

品號	TYPE	D-L	d	密著長 mm	F max	荷重 N/max	單價	品號	TYPE	D-L	d	密著長 mm	F max	荷重 N/max	單價	品號	TYPE	D-L	d	密著長 mm	F max	荷重 N/max	單價
03-05*	AM		0.35	2.5	1.8	3.4	•	06-55	AM		1.00	31.0	19.2	55.9	•	12-35	AM		1.20	10.2	12.2	35.3	•
10*	AM		0.38	3.3	3.5	6.9	•	(60)	AM		1.00	31.0	18.0	53.0	•	40	AM		1.30	14.3	14.0	41.2	•
15*	AM		0.45	7.0	5.3	10.3	•	(65)	AM		1.00	31.0	18.8	54.9	•	45	AM		1.30	14.3	15.8	46.1	•
20*	AM		0.50	11.5	7.0	13.7	•	(70)	AM		1.10	47.3	20.0	58.8	•	50	AM		1.30	14.3	17.5	51.0	•
(25)	AM		0.50	11.5	7.5	14.7	•	(80)	AM		1.10	48.4	22.4	65.9	•	55	AM		1.40	19.6	19.2	55.9	•
(30)	AM		0.55	20.4	9.0	17.7	•	08-10	AM		0.75	4.2	3.5	9.8	•	60	AM		1.40	19.6	21.0	61.8	•
04-05*	AM		0.40	2.3	1.7	3.9	•	15	AM		0.90	8.5	5.2	14.7	•	65	AM		1.50	26.3	22.7	64.7	•
10*	AM		0.45	3.4	3.5	6.9	•	20	AM		0.90	8.5	7.0	20.6	•	70	AM		1.50	26.3	24.5	71.6	•
15*	AM		0.50	5.1	5.2	10.8	•	25	AM		0.90	8.5	8.7	25.5	•	80	AM		1.60	36.8	28.0	82.4	•
20	AM		0.55	7.7	7.0	13.7	•	30	AM		0.90	8.5	10.5	30.4	•	13-10	AM		1.00	5.0	3.5	10.3	•
25	AM		0.60	11.7	8.7	17.7	•	35	AM		1.00	13.0	12.2	35.3	•	15	AM		1.20	8.4	5.2	14.7	•
30	AM		0.60	11.7	10.5	20.6	•	40	AM		1.00	13.0	14.0	41.2	•	20	AM		1.30	11.7	7.0	20.6	•
35	AM		0.65	17.6	12.2	24.0	•	45	AM		1.10	19.8	15.8	46.1	•	25	AM		1.30	11.7	8.7	25.5	•
(40)	AM		0.65	17.6	12.0	23.5	•	50	AM		1.10	19.8	17.5	51.0	•	30	AM		1.40	14.5	10.5	30.4	•
05-05*	AM		0.50	2.8	1.7	4.9	•	55	AM		1.20	31.2	19.2	55.9	•	35	AM		1.40	14.5	12.2	35.3	•
10	AM		0.60	4.2	3.5	9.8	•	60	AM		1.20	31.2	21.0	61.8	•	40	AM		1.40	14.5	14.0	41.2	•
15	AM		0.65	6.5	5.2	14.7	•	65	AM		1.20	31.2	22.7	64.7	•	45	AM		1.40	14.5	15.8	46.1	•
20	AM		0.65	6.5	7.0	20.6	•	70	AM		1.20	31.2	24.5	71.6	•	50	AM		1.40	14.5	17.5	51.0	•
25	AM		0.70	9.1	8.7	25.5	•	80	AM		1.30	44.2	28.0	82.4	•	55	AM		1.50	22.5	19.2	55.9	•
30	AM		0.75	12.7	10.5	30.4	•	10-10	AM		0.90	5.2	3.5	9.8	•	60	AM		1.50	22.5	21.0	61.8	•
35	AM		0.80	17.4	12.2	35.3	•	15	AM		1.00	7.7	5.2	14.7	•	65	AM		1.60	28.8	22.7	64.7	•
40	AM		0.85	23.8	14.0	41.2	•	20	AM		1.00	7.7	7.0	20.6	•	70	AM		1.60	28.8	24.5	71.6	•
45	AM		0.85	23.8	15.8	46.1	•	25	AM		1.10	11.0	8.7	25.5	•	80	AM		1.70	37.4	28.0	82.4	•
(50)	AM		0.90	23.8	15.0	43.5	•	30	AM		1.10	11.0	10.5	30.4	•	90	AM		1.70	37.4	31.5	92.9	•
(55)	AM		0.90	30.0	16.5	49.0	•	35	AM		1.20	16.2	12.2	35.3	•	14-15	AM		1.20	7.5	5.2	14.7	•
(60)	AM		0.90	30.0	18.0	53.0	•	40	AM		1.20	16.2	14.0	41.2	•	20	AM		1.30	9.8	7.0	20.6	•
(65)	AM		0.90	30.0	17.6	52.0	•	45	AM		1.30	22.1	15.8	46.1	•	25	AM		1.40	13.3	8.7	25.5	•
(70)	AM		0.90	30.0	19.6	58.8	•	50	AM		1.30	22.1	17.5	51.0	•	30	AM		1.40	13.3	10.5	30.4	•
06-05*	AM		0.55	2.8	1.7	4.9	•	55	AM		1.30	22.1	19.2	55.9	•	35	AM		1.40	13.3	12.2	35.3	•
10	AM		0.65	4.7	3.5	9.8	•	60	AM		1.40	32.1	21.0	61.8	•	40	AM		1.40	13.3	14.0	41.2	•
15	AM		0.75	8.0	5.2	14.7	•	65	AM		1.40	32.1	22.7	64.7	•	45	AM		1.50	17.3	15.8	46.1	•
20	AM		0.75	8.0	7.0	20.6	•	70	AM		1.40	32.1	24.5	71.6	•	50	AM		1.50	17.3	17.5	51.0	•
25	AM		0.85	13.6	8.7	25.5	•	80	AM		1.40	32.2	28.0	82.4	•	55	AM		1.50	17.3	19.2	55.9	•
30	AM		0.85	13.6	10.5	30.4	•	12-10	AM		1.00	5.5	3.5	10.3	•	60	AM		1.60	23.2	21.0	61.8	•
35	AM		0.90	18.0	12.2	35.3	•	15	AM		1.10	7.4	5.2	14.7	•	65	AM		1.60	23.2	22.7	64.7	•
40	AM		0.90	18.0	14.0	41.2	•	20	AM		1.10	7.4	7.0	20.6	•	70	AM		1.70	30.6	24.5	71.6	•
45	AM		0.90	18.0	15.8	46.1	•	25	AM		1.10	7.4	8.7	25.5	•	80	AM		1.70	30.6	28.0	82.4	•
50	AM		0.90	18.0	17.5	51.0	•	30	AM		1.20	10.2	10.5	30.4	•	90	AM		1.80	39.6	31.5	92.7	•

品號		d	密著長 mm	F max	荷重 N/max	單價
TYPE	D-L					
AM	16-15	1.30	7.8	5.2	14.7	•
	20	1.40	9.8	7.0	20.6	
	25	1.50	12.5	8.7	25.5	
	30	1.50	12.5	10.5	30.4	
	35	1.60	15.0	12.2	35.3	
	40	1.60	15.0	14.0	41.2	
	45	1.70	20.4	15.8	46.1	
	50	1.70	20.4	17.5	51.0	
	55	1.80	27.0	19.2	55.9	
	60	1.80	27.0	21.0	61.8	
	65	1.80	27.0	22.7	64.7	
	70	1.80	27.0	24.5	71.6	
	80	1.80	27.0	28.0	82.4	
	90	1.90	34.2	31.5	92.7	
AM	18-20	1.70	11.9	7.0	34.3	•
	25	1.80	14.4	8.7	42.2	
	30	1.80	14.4	10.5	51.0	
	35	1.80	14.4	12.2	59.8	
	40	1.80	14.4	14.0	68.6	
	45	2.00	22.0	15.8	77.5	
	50	2.00	22.0	17.5	85.3	
	55	2.00	22.0	19.2	94.1	
	60	2.00	22.0	21.0	103.0	
	65	2.20	34.1	22.7	110.8	
	70	2.20	34.1	24.5	119.6	
	80	2.20	34.1	28.0	137.3	
90	2.30	41.4	31.5	154.0		
100	2.30	41.4	35.0	171.6		
AM	20-20	1.80	11.7	7.0	34.3	•
	25	1.80	11.7	8.7	42.2	
	30	1.90	14.3	10.5	51.0	
	35	1.90	14.3	12.2	59.8	
	40	1.90	14.3	14.0	68.6	
	45	2.00	17.0	15.8	77.5	
	50	2.00	17.0	17.5	85.3	
	55	2.20	24.8	19.2	94.1	
	60	2.20	24.8	21.0	103.0	
	65	2.20	24.8	22.7	110.8	
	70	2.20	24.8	24.5	119.6	
	80	2.40	36.0	28.0	137.3	
	90	2.40	36.0	31.5	154.0	
	100	2.40	36.0	35.0	171.6	
AM	22-20	1.90	12.0	7.0	34.3	•
	25	2.00	14.0	8.7	42.2	
	30	2.00	14.0	10.5	51.0	
	35	2.00	14.0	12.2	59.8	
	40	2.00	14.0	14.0	68.6	
	45	2.30	23.0	15.8	77.5	
	50	2.30	23.0	17.5	85.3	
	55	2.30	23.0	19.2	94.1	
	60	2.30	23.0	21.0	103.0	
	65	2.40	30.0	22.7	110.8	
	70	2.40	30.0	24.5	119.6	
	80	2.40	30.0	28.0	137.3	
	90	2.60	40.0	31.5	154.0	
	100	2.60	40.0	35.0	171.6	
AM	27-30	2.30	14.0	10.5	51.0	•
	35	2.40	17.0	12.2	59.8	

品號		d	密著長 mm	F max	荷重 N/max	單價
TYPE	D-L					
AM	27-40	2.40	17.0	14.0	68.6	•
	45	2.40	18.0	15.8	77.5	
	50	2.60	23.0	17.5	85.3	
	55	2.60	23.0	19.2	94.1	
	60	2.60	23.0	21.0	103.0	
	65	2.80	31.0	22.7	110.8	
	70	2.80	31.0	24.5	119.6	
	80	2.80	31.0	28.0	137.3	
	90	3.00	43.5	31.5	154.0	
	100	3.00	43.5	35.0	171.6	

訂貨： 交期：

AM16-15

PS. 備註

- 荷重(N)=定數(N/mm)×壓縮量(mm)
- 密著長是參考值,製作時會有少許差異
- ★記號兩端面無研磨
- 耐熱溫度80°C
- 1N=0.101972 kgf

※(L)尺寸的容許壓縮量

- AM3-25Fmax=L×30%
- AM3-30Fmax=L×30%
- AM4-40Fmax=L×30%
- AM5-50Fmax=L×30%
- AM5-55Fmax=L×30%
- AM5-60Fmax=L×30%
- AM5-65Fmax=L×27%
- AM5-70Fmax=L×28%
- AM6-60Fmax=L×30%
- AM6-65Fmax=L×29%
- AM6-70Fmax=L×28%
- AM6-80Fmax=L×28%

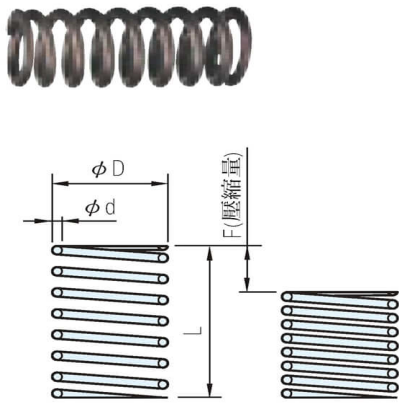

D		L	
≤13	>13	≤50	≥55
+0	+0	±1.5	±2.5
-0.5	-0.8		

材質	顏色
SWP	本色

規格	AY	AR	AF	AL	AT	AM	AH	AB
D				0.5				
2								3.9
3	N/mm 0.1	N/mm 0.3	N/mm 0.5	N/mm 1.0	N/mm 2.0	N/mm 2.0	2.9	4.9
4								
5								
6								
8	N/mm 0.2	N/mm 0.5	N/mm 1.0	N/mm 2.0	N/mm 2.9	N/mm 2.9	N/mm 5.9	N/mm 9.8
10								
12								
13								
14								
16								
18								
20	N/mm 0.5	N/mm 1.0	N/mm 2.9	N/mm 3.9	N/mm 4.9	N/mm 14.7	N/mm 19.6	29.4
22								
27								
FMAX	F=LX75%	F=LX60%	F=LX45%	F=LX40%	F=LX40%	F=LX35%	F=LX30%	F=LX25%

■ AH:Fmax(容許壓縮量)=LX30%

品號	d	密著長	F	荷重	單價	
						TYPE
AH	04-05*	0.45	2.7	1.5	4.9	•
	10*	0.45	2.7	3.0	8.8	
	15	0.55	5.8	4.5	13.7	
	20	0.60	8.4	6.0	17.7	
	25	0.65	12.4	7.5	22.6	
AH	30	0.65	12.4	9.0	26.5	•
	05-05*	0.60	3.3	1.5	8.8	
	10	0.70	5.5	3.0	17.7	
	15	0.75	7.5	4.5	26.5	
	20	0.75	7.5	6.0	35.3	
	25	0.85	13.6	7.5	44.1	
	(30)	0.85	13.6	7.5	44.3	
(35)	0.90	17.1	8.8	51.6		
AH	(40)	0.90	17.1	8.8	51.9	•
	06-05*	0.65	3.3	1.5	8.8	
	10	0.75	5.2	3.0	17.7	
	15	0.80	6.4	4.5	26.5	
	20	0.90	9.9	6.0	35.3	
	25	0.90	9.9	7.5	44.1	
	30	1.00	16.0	9.0	53.0	
	35	1.00	16.0	10.5	61.8	
	40	1.10	25.0	12.0	70.6	
	(45)	1.10	25.0	11.3	66.7	
	(50)	1.20	39.6	10.0	58.8	
	(55)	1.20	39.6	14.5	85.3	
	(60)	1.20	39.6	14.0	82.4	
(65)	1.20	39.6	14.0	82.4		
(70)	1.20	39.6	15.0	88.3		
AH	08-10	0.90	5.4	3.0	17.7	•
	15	1.00	8.0	4.5	26.5	
	20	1.10	11.5	6.0	35.3	
	25	1.10	11.5	7.5	44.1	
	30	1.20	16.8	9.0	53.0	
	35	1.20	16.8	10.5	61.8	
	40	1.20	16.8	12.0	70.6	
	45	1.30	24.7	13.5	79.4	
	50	1.30	24.7	15.0	88.3	
	55	1.40	35.0	16.5	97.1	

品號	d	密著長	F	荷重	單價			
						TYPE	D-L	max
AH	08-60	1.40	35.0	18.0	105.9	•		
	(65)	1.40	35.0	17.0	100.0			
	(70)	1.40	35.0	19.0	111.8			
AH	10-10	1.00	5.4	3.0	17.7	•		
	15	1.10	7.0	4.5	26.5			
	20	1.20	9.6	6.0	35.3			
	25	1.20	9.6	7.5	44.1			
	30	1.30	13.9	9.0	53.0			
	35	1.40	18.0	10.5	61.8			
	40	1.40	18.0	12.0	70.6			
	45	1.50	25.0	13.5	79.4			
	50	1.50	25.0	15.0	88.3			
	55	1.50	25.0	16.5	97.1			
	60	1.50	25.0	18.0	105.9			
	65	1.60	35.0	19.5	114.7			
	70	1.60	35.0	21.0	123.6			
	80	1.70	45.9	24.0	141.0			
	AH	12-10	1.20	6.9	3.0		17.7	•
		15	1.30	9.1	4.5		26.5	
20		1.30	9.1	6.0	35.3			
25		1.30	9.1	7.5	44.1			
30		1.40	11.9	9.0	53.0			
35		1.40	11.9	10.5	61.8			
40		1.50	15.4	12.0	70.6			
45		1.50	15.4	13.5	79.4			
50		1.60	20.4	15.0	88.3			
55		1.60	20.4	16.5	97.1			
60		1.70	26.8	18.0	105.9			
65		1.70	26.8	19.5	114.7			
70		1.80	35.1	21.0	123.6			
80		1.90	45.6	24.0	141.0			
AH		13-10	1.30	6.2	3.0	29.4	•	
		15	1.50	9.3	4.5	44.1		
	20	1.60	12.3	6.0	58.8			
	25	1.60	12.3	7.5	73.5			
	30	1.70	15.0	9.0	88.3			
	35	1.70	15.0	10.5	103.0			
	40	1.80	19.0	12.0	117.7			

品號	d	密著長	F	荷重	單價	
						TYPE
AH	13-45	1.90	25.0	13.5	132.4	•
	50	1.90	25.0	15.0	147.1	
	55	2.00	30.0	16.5	161.8	
	60	2.00	30.0	18.0	176.5	
	65	2.10	39.0	19.5	191.2	
	70	2.10	39.0	21.0	205.9	
	80	2.10	39.0	24.0	235.4	
	AH	14-15	1.60	10.4	4.5	
20		1.60	10.4	6.0	58.8	
25		1.60	10.4	7.5	73.5	
30		1.70	12.8	9.0	88.3	
35		1.70	12.8	10.5	103.0	
40		1.90	20.0	12.0	117.7	
45		1.90	20.0	13.5	132.4	
50		2.10	30.5	15.0	147.1	
55		2.10	30.5	16.5	161.8	
60		2.10	30.5	18.0	176.5	
65		2.20	37.4	19.5	191.2	
70		2.20	37.4	21.0	205.9	
80		2.30	47.2	24.0	235.4	
AH	16-15	1.70	10.2	4.5	44.1	•
	20	1.80	12.6	6.0	58.8	
	25	1.90	14.5	7.5	73.5	
	30	1.90	14.5	9.0	88.3	
	35	2.00	18.0	10.5	103.0	
	40	2.10	21.0	12.0	117.7	
	45	2.20	26.0	13.5	132.4	
	50	2.20	26.0	15.0	147.1	
	55	2.20	26.0	16.5	161.8	
	60	2.30	32.0	18.0	176.5	
	65	2.30	32.0	19.5	191.2	
	70	2.40	38.0	21.0	205.9	
AH	18-20	2.10	12.6	6.0	88.3	•
	25	2.20	15.4	7.5	109.8	
	30	2.20	15.4	9.0	132.4	
	35	2.30	18.4	10.5	154.0	
	40	2.40	21.6	12.0	176.5	

品號		d	密著長 mm	F max	荷重 N/max	單價
TYPE	D-L					
AH	18-45	2.50	25.0	13.5	199.1	•
	50	2.50	25.0	15.0	220.6	
	55	2.60	30.0	16.5	242.2	
	60	2.60	30.0	18.0	264.8	
	65	2.80	42.0	19.5	286.4	
	70	2.80	42.0	21.0	308.9	
	80	2.90	49.3	24.0	353.0	
	(90)	3.00	57.0	26.1	397.2	
	(100)	3.00	57.0	24.0	441.3	•
AH	20-20	2.20	12.7	6.0	88.3	
	25	2.30	15.0	7.5	109.8	
	30	2.30	15.0	9.0	132.4	
	35	2.50	20.0	10.5	154.0	
	40	2.50	20.0	12.0	176.5	
	45	2.50	20.0	13.5	199.1	
	50	2.60	22.8	15.0	220.6	
	55	2.60	22.8	16.5	242.2	
	60	2.80	30.8	18.0	264.8	
	65	2.80	30.8	19.5	286.4	
	70	3.00	42.0	21.0	308.9	
	80	3.00	42.0	24.0	353.0	
90	3.20	56.8	27.0	397.2		
100	3.20	56.8	30.0	441.3	•	
AH	22-20	2.30	12.7	6.0		88.3
	25	2.50	16.7	7.5		109.8
	30	2.50	16.7	9.0		132.4
	35	2.60	18.2	10.5		154.0
	40	2.80	25.0	12.0		176.5
	45	2.80	25.0	13.5		199.1
	50	2.80	25.0	15.0		220.6
	55	3.00	33.0	16.5		242.2
	60	3.00	33.0	18.0		264.8
	65	3.00	33.0	19.5		286.4
	70	3.20	43.0	21.0		308.9
	80	3.20	43.0	24.0	353.0	
(90)	3.20	43.0	26.1	397.2		
(100)	3.50	64.4	26.0	441.3	•	
AH	27-30	2.80	16.8	9.0		132.4
	35	2.80	16.8	10.5		154.0
	40	2.90	18.8	12.0		176.5
	45	2.90	19.4	13.5		199.1
	50	3.20	25.5	15.0		220.6
	55	3.20	25.5	16.5		242.2
	60	3.50	35.5	18.0		264.8
	65	3.50	35.5	19.5		286.4
	70	3.50	35.5	21.0		308.9
	80	3.50	35.5	24.0		353.0
	90	3.50	35.5	27.0		397.2
	100	4.00	68.0	30.0	441.3	

PS. 備註

- 荷重(N)=定數(N/mm)×壓縮量(mm)
- 密著長是參考值,製作時會有少許差異
- ★記號兩端面無研磨
- 耐熱溫度80°C
- 1N=0.101972 kgf

※(L)尺寸的容許壓縮量

- AH 5- 30Fmax=L × 25%
- AH 5- 35Fmax=L × 25%
- AH 5- 40Fmax=L × 22%
- AH 6- 45Fmax=L × 25%
- AH 6- 50Fmax=L × 20%
- AH 6- 55Fmax=L × 26%
- AH 6- 60Fmax=L × 23%
- AH 6- 65Fmax=L × 21%
- AH 6- 70Fmax=L × 21%
- AH 8- 65Fmax=L × 26%
- AH 8- 70Fmax=L × 27%
- AH18- 90Fmax=L × 29%
- AH18-100Fmax=L × 24%
- AH22- 90Fmax=L × 29%
- AH22-100Fmax=L × 26%

訂貨： 交期：

AH18-45

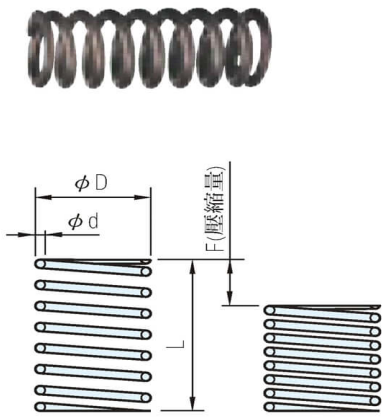

D		L	
≤ 13	> 13	≤ 50	≥ 55
+0	+0	± 1.5	± 2.5
-0.5	-0.8		

材質	顏色
SWP	本色

規格	AY	AR	AF	AL	AT	AM	AH	AB
D				0.5				
2								3.9
3	N/mm 0.1				N/mm 1.5	N/mm 2.0	2.9	4.9
4								
5								
6								
8	N/mm 0.2	N/mm 0.3	N/mm 0.5	N/mm 1.0	N/mm 2.0	N/mm 2.0	N/mm 5.9	N/mm 9.8
10								
12								
13								
14							N/mm 9.8	N/mm 19.6
16								29.4
18								
20		N/mm 0.5	N/mm 1.0	N/mm 2.9	N/mm 3.9	N/mm 4.9	N/mm 14.7	
22								
27								N/mm 29.4
F _{MAX}	F=LX75%	F=LX60%	F=LX45%	F=LX40%	F=LX40%	F=LX35%	F=LX30%	F=LX25%

■ AB:Fmax(容許壓縮量)=LX25%

品號	TYPE	D-L	d	密著長 mm	F max	荷重 N/max	單價
		10*	0.50	6.5	2.5	9.8	
		15*	0.55	10.5	3.8	14.7	
		20*	0.55	12.7	5.0	19.6	
		25*	0.60	17.4	6.3	24.5	
		30*	0.60	21.0	7.5	29.4	
		35*	0.65	24.0	8.8	34.3	
		40*	0.65	27.0	10.0	39.2	
AB	04-05*	0.50	3.0	1.3	5.9		
		10	0.60	6.0	2.5	12.3	
		15	0.65	9.8	3.8	18.1	
		20	0.70	12.6	5.0	24.5	
		25	0.75	16.5	6.3	30.4	
		30	0.75	20.3	7.5	36.8	
		35	0.80	24.0	8.8	43.1	
		40	0.80	28.0	10.0	49.0	
		45	0.80	29.0	11.3	55.4	
		50	0.85	34.0	12.5	61.3	
AB	05-05*	0.65	3.3	1.3	12.7		
		10	0.80	7.0	2.5	24.5	
		15	0.80	7.0	3.8	37.3	
		20	0.90	13.0	5.0	49.0	
		25	0.90	13.0	6.3	61.8	
		30	1.00	21.0	7.5	73.5	
		35	1.00	25.0	8.8	86.3	
		40	1.00	25.0	10.0	98.1	
		45	1.10	31.0	11.3	110.8	
		50	1.10	34.0	12.5	122.6	
		55	1.10	39.0	13.8	135.3	
		60	1.10	43.0	15.0	147.1	
		65	1.20	46.0	16.3	159.8	
		70	1.20	50.0	17.5	171.6	
AB	06-05*	0.70	3.5	1.3	12.7		
		10	0.80	7.0	2.5	24.5	
		15	0.90	7.5	3.8	37.3	
		20	1.00	11.5	5.0	49.0	
		25	1.10	17.5	6.3	61.8	
		30	1.10	19.5	7.5	73.5	

品號	TYPE	D-L	d	密著長 mm	F max	荷重 N/max	單價
		40	1.20	28.0	10.0	98.1	
		45	1.20	30.0	11.3	110.8	
		50	1.20	32.0	12.5	122.6	
		55	1.20	32.0	13.8	135.3	
		60	1.30	43.0	15.0	147.1	
		65	1.30	46.0	16.3	159.8	
		70	1.30	50.0	17.5	171.6	
		80	1.40	57.0	20.0	196.1	
AB	08-10	1.00	6.0	2.5	24.5		
		15	1.20	10.8	3.8	37.3	
		20	1.20	11.5	5.0	49.0	
		25	1.30	17.0	6.3	61.8	
		30	1.30	17.0	7.5	73.5	
		35	1.40	24.5	8.8	86.3	
		40	1.40	25.2	10.0	98.1	
		45	1.50	32.0	11.3	110.8	
		50	1.50	33.0	12.5	122.6	
		55	1.50	36.5	13.8	135.3	
		60	1.50	36.5	15.0	147.1	
		65	1.60	48.0	16.3	159.8	
		70	1.60	48.0	17.5	171.6	
		80	1.60	55.0	20.0	196.1	
AB	10-10	1.20	6.0	2.5	24.5		
		15	1.30	8.5	3.8	37.3	
		20	1.40	12.0	5.0	49.0	
		25	1.50	16.5	6.3	61.8	
		30	1.50	17.0	7.5	73.5	
		35	1.60	23.0	8.8	86.3	
		40	1.60	24.0	10.0	98.1	
		45	1.70	30.0	11.3	110.8	
		50	1.70	31.5	12.5	122.6	
		55	1.80	40.0	13.8	135.3	
		60	1.80	40.0	15.0	147.1	
		65	1.80	43.0	16.3	159.8	
		70	1.80	43.0	17.5	171.6	
		80	1.80	54.0	20.0	196.1	
AB	12-10	1.40	6.5	2.5	24.5		

品號	TYPE	D-L	d	密著長 mm	F max	荷重 N/max	單價
		20	1.60	12.5	5.0	49.0	
		25	1.60	13.6	6.3	60.8	
		30	1.70	18.0	7.5	73.5	
		35	1.80	22.5	8.8	85.3	
		40	1.80	24.0	10.0	98.1	
		45	1.80	24.0	11.3	109.8	
		50	2.00	34.0	12.5	122.6	
		55	2.00	38.0	13.8	134.4	
		60	2.00	40.0	15.0	147.1	
		65	2.00	42.0	16.3	158.9	
		70	2.10	48.5	17.5	171.6	
		80	2.10	52.5	20.0	196.1	
AB	13-10	1.60	6.4	2.5	49.0		
		15	1.80	11.0	3.8	74.5	
		20	1.80	11.0	5.0	98.1	
		25	2.00	17.0	6.3	123.6	
		30	2.00	18.0	7.5	147.1	
		35	2.10	22.0	8.8	172.6	
		40	2.10	22.0	10.0	196.1	
		45	2.30	32.0	11.3	221.6	
		50	2.30	32.0	12.5	245.2	
		55	2.40	40.0	13.8	270.7	
		60	2.40	42.0	15.0	294.2	
		65	2.40	42.0	16.3	319.7	
		70	2.50	50.0	17.5	343.2	
		80	2.50	50.0	20.0	392.3	
AB	14-15	1.80	9.0	3.8	72.6		
		20	2.00	13.0	5.0	98.1	
		25	2.00	14.0	6.3	121.6	
		30	2.10	18.0	7.5	147.1	
		35	2.10	23.0	8.8	170.6	
		40	2.30	26.3	10.0	196.1	
		45	2.30	27.6	11.3	219.7	
		50	2.40	31.0	12.5	245.2	
		55	2.50	37.5	13.8	268.7	
		60	2.50	41.0	15.0	294.2	
		65	2.50	43.5	16.3	317.7	

品號		d	密著長 mm	F max	荷重 N/max	單價
TYPE	D-L					
AB	14-70	2.60	48.0	17.5	343.2	•
	80	2.60	52.0	20.0	392.3	
AB	16-15	2.00	10.0	3.8	74.5	•
	20	2.10	12.5	5.0	98.1	
	25	2.30	17.0	6.3	123.6	
	30	2.30	18.5	7.5	147.1	
	35	2.40	21.5	8.8	172.6	
	40	2.40	21.5	10.0	196.1	
	45	2.50	27.5	11.3	221.6	
	50	2.50	27.5	12.5	245.2	
	55	2.60	32.0	13.8	270.7	
	60	2.60	32.0	15.0	294.2	
	65	2.80	46.0	16.3	319.7	
	70	2.80	46.0	17.5	343.2	
	80	2.90	55.0	20.0	392.3	
	AB	18-20	2.50	13.5	5.0	
25		2.60	17.0	6.3	185.3	
30		2.60	17.0	7.5	220.6	
35		2.80	23.5	8.8	258.9	
40		2.90	27.5	10.0	294.2	
45		2.90	27.5	11.3	332.4	
50		3.00	33.0	12.5	367.7	
55		3.00	33.0	13.8	406.0	
60		3.20	43.0	15.0	441.3	
65		3.20	44.5	16.3	479.5	
70		3.20	44.5	17.5	514.8	
80		3.40	58.0	20.0	588.4	
90	3.40	61.0	22.5	661.9		
100	3.50	71.0	25.0	735.5		
AB	22-20	2.80	13.5	5.0	147.1	•
	25	2.90	16.0	6.3	185.3	
	30	3.00	18.0	7.5	220.6	
	35	3.00	18.0	8.8	258.9	
	40	3.20	24.0	10.0	294.2	
	45	3.20	24.0	11.3	332.4	
	50	3.50	36.0	12.5	367.7	
	55	3.50	36.0	13.8	406.0	
	60	3.50	36.0	15.0	441.3	
	65	3.60	45.0	16.3	479.5	
	70	3.60	45.0	17.5	514.8	
	80	3.80	57.0	20.0	588.4	
90	3.80	57.0	22.5	661.9		
100	4.00	72.0	25.0	735.5		
AB	27-30	3.50	19.0	7.5	220.6	•
	35	3.60	21.0	8.8	258.9	
	40	3.60	21.0	10.0	294.2	
	45	3.80	30.0	11.3	332.4	
	50	3.80	30.0	12.5	367.7	
	55	4.00	38.0	13.8	406.0	
	60	4.00	38.0	15.0	441.3	
	65	4.00	38.0	16.3	479.5	
	70	4.00	38.0	17.5	514.8	
	80	4.50	57.0	20.0	588.4	
	90	4.50	63.0	22.5	661.9	
100	4.50	67.0	25.0	735.5		

PS: 備註

- 荷重(N)=定數(N/mm)×壓縮量(mm)
- 密著長是參考值,製作時會有少許差異
- ★記號兩端面無研磨
- 耐熱溫度80°C
- 1N=0.101972 kgf

訂貨： 交期： 天

AB14-70

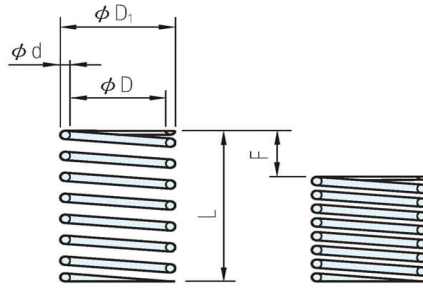

D		L	
≤8.5	≥10.6	≤50	≥60
±0.3	±0.4	±1	±2

TYPE	材質	顏色
NAL . NAM	SWP	本色

銷徑	品號		D ₁	D	d	L	F	密著長	定數	F=L×40%	單價	銷徑	品號		D ₁	D	d	L	F	密著長	定數	F=L×32%	單價
	TYPE	D-L	外徑	內徑	線徑	自由長				max			荷重	N(max)	TYPE	D-L	外徑	內徑				線徑	
5	NAL	5.5-30	7.0	5.5	0.75	30	12	10.9	1.1	13.7	•	5	NAM	5.5-30	7.3	5.5	0.9	30	9.6	13.1	2.1	20.6	•
		35				14	12.0	1.0	35					11.2				14.9	1.8				
		40				16	13.5	0.9	40					12.8				16.2	1.6				
		45				18	15.0	0.8	45					14.4				18.0	1.4				
		50				20	16.5	0.7	50					16.0				19.8	1.3				
6	NAL	6.5-30	8.1	6.5	0.8	30	12	9.6	1.1	13.7	•	6	NAM	6.5-30	8.5	6.5	1.0	30	9.6	14.0	2.1	20.6	•
		35				14	10.8	1.0	35					11.2				15.5	1.8				
		40				16	12.0	0.9	40					12.8				17.5	1.6				
		45				18	13.2	0.8	45					14.4				19.5	1.4				
		50				20	14.4	0.7	50					16.0				21.0	1.3				
8	NAL	8.5-30	10.5	8.5	1.0	30	12	9.8	1.7	20.6	•	8	NAM	8.5-30	10.7	8.5	1.1	30	9.6	9.4	2.9	27.5	•
		35				14	10.8	1.5	35					11.2				10.5	2.5				
		40				16	12.0	1.3	40					12.8				11.6	2.1				
		45				18	13.0	1.1	45					14.4				12.7	1.9				
		50				20	14.0	1.0	50					16.0				13.8	1.7				
		60				24	16.5	0.9	60					19.2				16.0	1.4				
10	NAL	10.6-30	12.8	10.6	1.1	30	12	9.1	1.7	20.6	•	10	NAM	10.6-30	13.2	10.6	1.3	30	9.6	11.4	2.9	27.5	•
		35				14	9.9	1.5	35					11.2				12.7	2.5				
		40				16	11.0	1.3	40					12.8				14.0	2.1				
		45				18	12.1	1.1	45					14.4				15.3	1.9				
		50				20	12.7	1.0	50					16.0				16.6	1.7				
		60				24	14.9	0.9	60					19.2				19.2	1.4				
13	NAL	13.6-35	16.4	13.6	1.4	35	14	12.3	2.0	27.5	•	13	NAM	13.6-35	16.8	13.6	1.6	35	11.2	14.4	3.1	34.3	•
		40				16	13.3	1.7	40					12.8				15.6	2.7				
		45				18	14.7	1.5	45					14.4				17.2	2.4				
		50				20	15.8	1.4	50					16.0				18.4	2.1				
		60				24	18.2	1.1	60					19.2				20.8	1.8				
		60				24	18.2	1.1	60					19.2				20.8	1.8				
16	NAL	16.6-35	19.8	16.6	1.6	35	14	13.6	2.0	27.5	•	16	NAM	16.6-35	20.2	16.6	1.8	35	11.2	15.3	3.1	34.3	•
		40				16	14.8	1.7	40					12.8				16.7	2.7				
		45				18	16.0	1.5	45					14.4				18.5	2.4				
		50				20	17.2	1.4	50					16.0				19.4	2.1				
		60				24	20.0	1.1	60					19.2				22.5	1.8				
		60				24	20.0	1.1	60					19.2				22.5	1.8				

PS. 備註

- 荷重(N)=定數(N/mm)×壓縮量(mm)
- 密著長是參考值製作時會有少許差異
- 耐熱溫度80°C
- 1N=0.101972 kgf
- NAL/NAM全部兩端研磨

訂貨： 交期：

NAL5.5-30

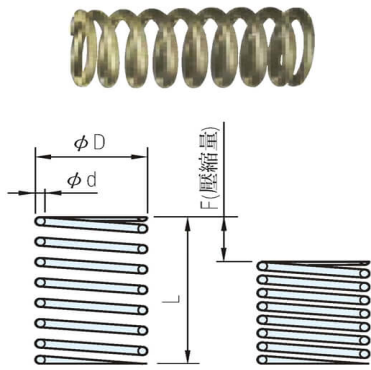

D		L	
≤10	≥12	≤50	≥55
+0	+0	±1.5	±2.5
-0.5	-0.8		

材質	顏色
SUS304	本色

TYPE D	OV	OY	OR	OF	OL	OT	OM	OH	OB
2		0.05	0.2	0.3	0.5				
3									
4	N/mm 0.05	N/mm 0.098	N/mm 0.29	N/mm 0.49	N/mm 0.98	N/mm 1.5	N/mm 2.0	N/mm 2.9	N/mm 4.9
5									
6									
8									
10									
12									
13									
14		N/mm 0.2							
16									
20		0.3	0.5	0.98	2.9	3.9	4.9	14.7	29.4
F MAX	F=LX70 %	F=LX75 %	F=LX60 %	F=LX45 %	F=LX40 %	F=LX40 %	F=LX35 %	F=LX30 %	F=LX25 %

■ OR:Fmax(容許壓縮量)=LXFa %

品號							品號							品號														
TYPE	D-L	d	密著長 mm	F max	荷重 N/max	Fa %	單價	TYPE	D-L	d	密著長 mm	F max	荷重 N/max	Fa %	單價	TYPE	D-L	d	密著長 mm	F max	荷重 N/max	Fa %	單價					
OR	02-05*	0.18	2.0	2.5	0.49	50	•	OR	06-35*	0.55	11.0	21	6.2	60	•	OR	13-20*	0.7	4.7	12	3.5	60	•					
	10*	0.18	2.0	5	0.98				40*	0.55	11.0	24	7.1				25*	0.8	8.0	15	4.4							
	15*	0.23	6.0	7.5	1.5				45*	0.6	17.4	27	7.9				30*	0.8	8.0	18	5.3							
	20*	0.23	6.0	10	2.0				50*	0.6	17.4	30	8.8				35*	0.8	8.0	21	6.2							
	25*	0.26	11.2	12.5	2.5				60*	0.65	23.4	36	10.6				40*	0.9	12.8	24	7.1							
	30*	0.26	11.2	15	2.9				70*	0.65	23.4	42	12.4				45*	0.9	12.8	27	7.9							
OR	03-05*	0.23	1.6	3	0.9	60	•	OR	08-10*	0.45	2.6	6	1.8	60	•	OR	50*	0.9	12.8	30	8.8	60	•					
	10*	0.25	2.1	6	1.8				15*	0.5	3.6	9	2.6				60*	1.0	21.0	36	10.6							
	15*	0.3	4.5	9	2.6				20*	0.5	3.6	12	3.5				70*	1.0	21.0	42	12.4							
	20*	0.3	4.5	12	3.5				25*	0.55	5.9	15	4.4				80*	1.0	21.0	48	14.1							
	25*	0.32	6.4	15	4.4				30*	0.65	10.4	18	5.3				16-15*	0.75	4.3	9	2.6							
	30*	0.32	6.4	18	5.3				35*	0.65	10.4	21	6.2					20*	0.8	5.4	12			3.5				
	35*	0.35	9.8	21	6.2				40*	0.7	15.4	24	7.1					25*	0.9	7.7	15			4.4				
	40*	0.35	9.8	24	7.1				45*	0.75	21.0	22	7.9					30*	0.9	7.7	18			5.3				
OR	04-05*	0.26	1.4	3	0.9	60	•	OR	50*	0.75	21.0	27	8.8	55	60	•	OR	35*	1.0	12.0	21	6.2	60	•				
	10*	0.29	2.0	6	1.8				60*	0.8	27.6	31	10.6	52				40*	1.0	12.0	24	7.1						
	15*	0.32	3.0	9	2.6				70*	0.8	27.6	40	12.4	57				45*	1.0	12.0	27	7.9						
	20*	0.38	6.1	12	3.5				80*	0.8	27.6	48	14.1	60				50*	1.1	19.0	30	8.8						
	25*	0.38	6.1	15	4.4				10-10*	0.55	3.3	6	1.8	60				•	OR	60*	1.1	19.0			36	10.6		
	30*	0.4	8.0	18	5.3					15*	0.6	4.2	9							2.6	70*	1.2			26.4	42	12.4	
	35*	0.4	8.0	21	6.2					20*	0.65	6.2	12							3.5	80*	1.2			26.4	48	14.1	
	40*	0.45	14.4	24	7.1					25*	0.65	6.2	15							4.4	20-20*	1.0			6.0	12	5.9	
	45*	0.45	14.4	27	7.9				30*	0.7	8.4	18	5.3	25*				1.1	7.7	15		7.4						
	50*	0.45	14.4	30	8.8				35*	0.7	8.4	21	6.2	30*				1.1	7.7	18		8.8						
60*	0.5	23.0	36	10.6	40*	0.7	8.4	24	7.1	35*	1.2	10.8	21	10.3														
OR	05-05*	0.3	1.65	3	0.9	60	•	OR	45*	0.8	15.2	27	7.9	60	•	OR	40*	1.2	10.8	24	11.8	60	•					
	10*	0.35	2.71	6	1.8				50*	0.8	15.2	30	8.8				45*	1.3	14.3	27	13.2							
	15*	0.38	3.61	9	2.6				60*	0.85	20.4	36	10.6				50*	1.3	14.3	30	14.7							
	20*	0.38	3.61	12	3.5				70*	0.85	20.4	42	12.4				60*	1.4	19.6	36	17.7							
	25*	0.45	7.43	15	4.4				80*	0.85	20.4	48	14.1				70*	1.4	19.6	42	20.6							
	30*	0.45	7.43	18	5.3				12-15*	0.6	3.5	9	2.6				60	•	OR	80*	1.5			27.0	48	23.5		
	35*	0.5	12.25	21	6.2					20*	0.7	5.6	12							3.5	20-20*			1.1	7.7	15	7.4	
	40*	0.5	12.25	24	7.1					25*	0.7	5.6	15							4.4				25*	1.1	7.7	18	8.8
	45*	0.5	12.25	27	7.9					30*	0.8	9.6	18							5.3				30*	1.1	7.7	18	8.8
	50*	0.55	19.53	30	8.8				35*	0.8	9.6	21	6.2				35*	1.2	10.8	21				10.3				
60*	0.55	19.53	36	10.6	40*	0.8	9.6	24	7.1	40*	1.2	10.8	24	11.8														
OR	06-05*	0.32	1.5	3	0.9	60	•	OR	45*	0.9	16.2	27	7.9	60	•	OR	45*	1.3	14.3	27	13.2	60	•					
	10*	0.4	3.0	6	1.8				45*	0.9	16.2	30	8.8				50*	1.3	14.3	30	14.7							
	15*	0.4	3.0	9	2.6				50*	0.9	16.2	36	10.6				60*	1.4	19.6	36	17.7							
	20*	0.5	7.0	12	3.5				60*	0.9	16.2	36	10.6				70*	1.4	19.6	42	20.6							
	25*	0.5	7.0	15	4.4				70*	1.0	26.0	42	12.4				80*	1.4	19.6	42	20.6							
	30*	0.5	7.0	18	5.3				80*	1.0	26.0	48	14.1				13-15*	0.7	4.7	9	2.6							

訂貨： 品號 交期： 1 天
OR02-05

PS. 備註

- 荷重(N)=定數(N/mm)×壓縮量(mm)
- 密著長是參考值，製作時會有少許差異
- *OR 型兩端皆不研磨
- 耐熱溫度 80°C
- 1N=0.101972 kgf

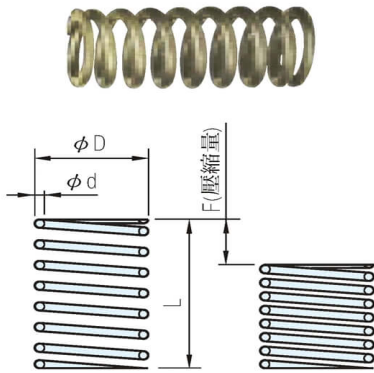

D		L	
≤10	≥12	≤50	≥55
+0	+0	±1.5	±2.5
-0.5	-0.8		

材質	顏色
SUS304	本色

TYPE	OV	OY	OR	OF	OL	OT	OM	OH	OB
D									
2		0.05	0.2	0.3	0.5				
3									
4	N/mm 0.05	N/mm 0.098	N/mm 0.29	N/mm 0.49	N/mm 0.98	N/mm 1.5	N/mm 2.0	N/mm 2.9	N/mm 4.9
5									
6									
8									
10									
12						N/mm 2.0	N/mm 2.9	N/mm 5.9	N/mm 9.8
13									
14		N/mm 0.2						N/mm 9.8	N/mm 19.6
16									
20		0.3	0.5	0.98	2.9	3.9	4.9	14.7	29.4
F _{MAX}	F=LX70%	F=LX75%	F=LX60%	F=LX45%	F=LX40%	F=LX40%	F=LX35%	F=LX30%	F=LX25%

OF:Fmax(容許壓縮量)=LX45%

品號	TYPE	D-L	d	密著長 mm	F max	荷重 N/max	單價
02-05*	OF	0.2	2.35	2.25	0.66		
10*	OF	0.2	2.35	4.5	1.3		
15*	OF	0.26	7.8	6.7	2.0		
20*	OF	0.26	7.8	9.0	2.7		
25*	OF	0.29	13.6	11.2	3.3		
30*	OF	0.29	13.6	13.5	4.0		
03-05*	OF	0.26	1.8	2.25	1.1		
10*	OF	0.32	3.5	4.5	2.2		
15*	OF	0.32	3.5	6.7	3.2		
20*	OF	0.35	6.3	9.0	4.4		
25*	OF	0.35	6.3	11.2	5.5		
30*	OF	0.4	12.4	13.5	6.6		
35*	OF	0.4	12.4	15.7	7.6		
40*	OF	0.4	12.4	18.0	8.8		
04-05*	OF	0.32	2.0	2.25	1.1		
10*	OF	0.35	3.0	4.5	2.2		
15*	OF	0.4	5.2	6.7	3.2		
20*	OF	0.4	5.2	9.0	4.4		
25*	OF	0.45	9.5	11.2	5.5		
30*	OF	0.45	9.5	13.5	6.6		
35*	OF	0.5	15.5	15.7	7.6		
40*	OF	0.5	15.5	18.0	8.8		
45*	OF	0.5	15.5	20.0	9.8		
50*	OF	0.5	15.5	22.5	10.8		
60*	OF	0.55	22.6	27.0	12.7		
05-05*	OF	0.35	2.01	2.25	1.1		
10*	OF	0.4	3.2	4.5	2.2		
15*	OF	0.4	3.2	6.75	3.3		
20*	OF	0.45	4.95	9.0	4.4		
25*	OF	0.45	4.95	11.25	5.5		
30*	OF	0.5	7.75	13.5	6.7		
35*	OF	0.5	7.75	15.75	7.7		
40	OF	0.6	19.5	18.0	8.8		
45	OF	0.6	19.5	20.25	10.0		
50	OF	0.6	19.5	22.5	11.2		
60	OF	0.65	27.95	27.0	13.4		
06-05*	OF	0.4	2.2	2.25	1.1		
10*	OF	0.5	5.0	4.5	2.2		
15*	OF	0.55	7.7	6.7	3.2		
20*	OF	0.55	7.7	9.0	4.4		
25	OF	0.6	10.8	11.2	5.5		
30	OF	0.65	15.6	13.5	6.6		

品號	TYPE	D-L	d	密著長 mm	F max	荷重 N/max	單價
06-35	OF	0.65	15.6	15.7	7.6		
40	OF	0.65	15.6	18.0	8.8		
45	OF	0.65	15.6	20.0	9.8		
50	OF	0.7	23.1	22.5	10.8		
60	OF	0.7	23.1	27.0	12.7		
70	OF	0.75	30.8	31.5	14.7		
08-10	OF	0.6	5.4	4.5	2.2		
15	OF	0.65	7.2	6.7	3.2		
20	OF	0.7	10.5	9.0	4.4		
25	OF	0.7	10.5	11.2	5.5		
30	OF	0.75	13.5	13.5	6.6		
35	OF	0.75	13.5	15.7	7.6		
40	OF	0.8	18.4	18.0	8.8		
45	OF	0.8	18.4	20.0	9.8		
50	OF	0.8	18.4	22.5	10.8		
60	OF	0.85	26.4	27.0	12.7		
70	OF	0.85	26.4	31.5	14.7		
80	OF	0.85	26.4	36.0	17.7		
10-10	OF	0.65	4.6	4.5	2.2		
15	OF	0.65	4.6	6.7	3.2		
20	OF	0.8	9.6	9.0	4.4		
25	OF	0.8	9.6	11.2	5.5		
30	OF	0.85	12.8	13.5	6.6		
35	OF	0.85	12.8	15.7	7.6		
40	OF	0.9	17.0	18.0	8.8		
45	OF	0.9	17.0	20.0	9.8		
50	OF	0.9	17.0	22.5	10.8		
60	OF	1.0	28.0	27.0	12.7		
70	OF	1.0	28.0	31.5	14.7		
80	OF	1.0	28.0	36.0	17.7		
12-15	OF	0.8	6.8	6.7	3.2		
20	OF	0.8	6.8	9.0	4.4		
25	OF	0.8	6.8	11.2	5.5		
30	OF	0.9	10.8	13.5	6.6		
35	OF	1.0	17.0	15.7	7.6		
40	OF	1.0	17.0	18.0	8.8		
45	OF	1.0	17.0	20.0	9.8		
50	OF	1.1	26.4	22.5	10.8		
60	OF	1.1	26.4	27.0	12.7		
70	OF	1.1	26.4	31.5	14.7		
80	OF	1.2	39.6	36.0	17.7		
13-15	OF	0.8	5.6	6.7	3.2		

品號	TYPE	D-L	d	密著長 mm	F max	荷重 N/max	單價
13-20	OF	0.8	5.6	9.0	4.4		
25	OF	0.85	7.2	11.2	5.5		
30	OF	1.0	14.0	13.5	6.6		
35	OF	1.0	14.0	15.7	7.6		
40	OF	1.0	14.0	18.0	8.8		
45	OF	1.1	21.5	20.0	9.8		
50	OF	1.1	21.5	22.5	10.8		
60	OF	1.1	21.5	27.0	12.7		
70	OF	1.2	30.0	31.5	14.7		
80	OF	1.2	30.0	36.0	17.7		
16-15	OF	0.9	5.6	6.7	3.2		
20	OF	1.0	7.7	9.0	4.4		
25	OF	1.0	7.7	11.2	5.5		
30	OF	1.1	12.1	13.5	6.6		
35	OF	1.1	12.1	15.7	7.6		
40	OF	1.2	18.0	18.0	8.8		
45	OF	1.2	18.0	20.0	9.8		
50	OF	1.2	18.0	22.5	10.8		
60	OF	1.3	26.0	27.0	12.7		
70	OF	1.3	26.0	31.5	14.7		
80	OF	1.4	35.0	36.0	17.7		
20-20	OF	1.2	7.2	9.0	8.8		
25	OF	1.3	9.1	11.3	11.1		
30	OF	1.4	11.9	13.5	13.2		
35	OF	1.4	11.9	15.8	15.5		
40	OF	1.5	15.8	18.0	17.7		
45	OF	1.5	15.8	20.3	19.9		
50	OF	1.6	20.8	22.5	22.1		
60	OF	1.6	20.8	27.0	26.5		
70	OF	1.7	26.4	31.5	30.9		
80	OF	1.7	26.4	36.0	35.3		

訂貨： 交期： 天
OF02-05

PS. 備註

- 荷重(N)=定數(N/mm)×壓縮量(mm)
- 密著長是參考值,製作時會有少許差異
- ★記號兩端皆不研磨
- 耐熱溫度80°C
- 1N=0.101972 kgf

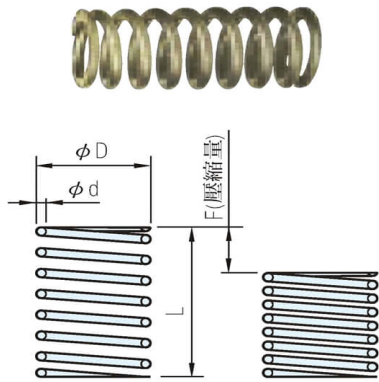

D		L	
≤10	≥12	≤50	≥55
+0 -0.5	+0 -0.8	±1.5	±2.5

材質	顏色
SUS304	本色

TYPE	OV	OY	OR	OF	OL	OT	OM	OH	OB
D									
2		0.05	0.2	0.3	0.5				
3									
4	N/mm 0.05	N/mm 0.098	N/mm 0.29	N/mm 0.49	N/mm 0.98	N/mm 1.5	N/mm 2.0	N/mm 2.9	N/mm 4.9
5									
6									
8									
10									
12									
13		N/mm 0.2							
14								N/mm 9.8	
16									N/mm 19.6
20		0.3	0.5	0.98	2.9	3.9	4.9	14.7	29.4
F _{MAX}	F=LX70%	F=LX75%	F=LX60%	F=LX45%	F=LX40%	F=LX40%	F=LX35%	F=LX30%	F=LX25%

■ OL:Fmax(容許壓縮量)=LX40%

品號	d	密著長	F	荷重	單價
TYPE	D-L	mm	max	N/max	
OL	02-05*	0.2	1.65	2.0	0.98
	10*	0.26	5.07	4.0	1.96
	15*	0.26	5.07	6.0	2.94
	20*	0.3	9.9	8.0	3.92
	25*	0.32	14.1	10.0	4.90
	30*	0.32	14.1	12.0	5.88
OL	03-05*	0.3	2.0	2.0	2.0
	10*	0.35	3.7	4.0	3.9
	15*	0.4	6.6	6.0	5.9
	20*	0.4	6.6	8.0	7.8
	25*	0.45	11.7	10.0	9.8
	30*	0.45	11.7	12.0	11.8
	35*	0.45	11.7	14.0	13.7
40*	0.5	20.0	16.0	15.7	
OL	04-05*	0.35	2.1	2.0	2.0
	10*	0.45	5.3	4.0	3.9
	15*	0.45	5.3	6.0	5.9
	20*	0.5	8.0	8.0	7.8
	25*	0.5	8.0	10.0	9.8
	30*	0.55	12.7	12.0	11.8
	35*	0.55	12.7	14.0	13.7
	40	0.6	19.8	16.0	15.7
	45	0.6	19.8	18.0	17.7
	50	0.6	19.8	20.0	19.6
60	0.65	29.9	24.0	23.5	
OL	05-05*	0.4	2.2	2.0	2.0
	10*	0.5	4.75	4.0	3.9
	15*	0.5	4.75	6.0	5.9
	20*	0.55	6.88	8.0	7.8
	25*	0.55	6.88	10.0	9.8
	30	0.65	14.95	12.0	11.8
	35	0.65	14.95	14.0	13.7
	40	0.65	14.95	16.0	15.7
	45	0.7	21.7	18.0	17.7
	50	0.7	21.7	20.0	19.6
	60	0.75	30.75	24.0	23.5
OL	06-05*	0.45	2.3	2.0	2.0
	10*	0.55	4.4	4.0	3.9
	15*	0.55	4.4	6.0	5.9
	20	0.65	8.5	8.0	7.8
	25	0.65	8.5	10.0	9.8
	30	0.7	12.6	12.0	11.8

品號	d	密著長	F	荷重	單價
TYPE	D-L	mm	max	N/max	
OL	06-35	0.7	12.6	14.0	13.7
	40	0.7	12.6	16.0	15.7
	45	0.75	17.3	18.0	17.7
	50	0.75	17.3	20.0	19.6
	60	0.8	24.8	24.0	23.5
	70	0.8	24.8	28.0	27.5
	OL	08-10	0.65	4.6	4.0
15		0.75	8.3	6.0	5.9
20		0.75	8.3	8.0	7.8
25		0.75	8.3	10.0	9.8
30		0.8	10.4	12.0	11.8
35		0.8	10.4	14.0	13.7
40		0.8	10.4	16.0	15.7
45		0.85	14.5	18.0	17.7
50		0.85	14.5	20.0	19.6
60		0.9	18.0	24.0	23.5
70	1.0	30.0	28.0	27.5	
80	1.0	30.0	32.0	31.4	
OL	10-10	0.75	4.7	4.0	3.9
	15	0.8	6.2	6.0	5.9
	20	0.8	6.2	8.0	7.8
	25	0.9	9.5	10.0	9.8
	30	0.9	9.5	12.0	11.8
	35	0.9	9.5	14.0	13.7
	40	1.0	15.5	16.0	15.7
	45	1.0	15.5	18.0	17.7
	50	1.0	15.5	20.0	19.6
	60	1.1	23.7	24.0	23.5
	70	1.1	23.7	28.0	27.5
	80	1.1	23.7	32.0	31.4
	OL	12-15	0.9	6.5	6.0
20		1.0	9.0	8.0	7.8
25		1.0	9.0	10.0	9.8
30		1.1	12.5	12.0	11.8
35		1.1	12.5	14.0	13.7
40		1.2	17.0	16.0	15.7
45		1.2	17.0	18.0	17.7
50		1.2	17.0	20.0	19.6
60		1.3	24.0	24.0	23.5
70		1.3	24.0	28.0	27.5
80	1.4	32.0	32.0	31.4	
OL	13-15	0.9	5.4	6.0	5.9

品號	d	密著長	F	荷重	單價
TYPE	D-L	mm	max	N/max	
OL	13-20	1.0	8.25	8.0	7.8
	25	1.0	8.25	10.0	9.8
	30	1.1	12.1	12.0	11.8
	35	1.1	12.1	14.0	13.7
	40	1.1	12.1	16.0	15.7
	45	1.2	16.8	18.0	17.7
	50	1.2	16.8	20.0	19.6
	60	1.2	16.8	24.0	23.5
	70	1.4	35.0	28.0	27.5
80	1.4	35.0	32.0	31.4	
OL	16-15	1.1	7.7	6.0	5.9
	20	1.1	7.7	8.0	7.8
	25	1.2	10.8	10.0	9.8
	30	1.2	10.8	12.0	11.8
	35	1.3	14.3	14.0	13.7
	40	1.3	14.3	16.0	15.7
	45	1.4	19.6	18.0	17.7
	50	1.4	19.6	20.0	19.6
	60	1.4	19.6	24.0	23.5
	70	1.5	27.0	28.0	27.5
80	1.5	27.0	32.0	31.4	
OL	20-20	1.6	10.4	8.0	23.5
	25	1.6	10.4	10.0	29.4
	30	1.7	12.8	12.0	35.3
	35	1.7	12.8	14.0	41.2
	40	1.8	15.3	16.0	47.1
	45	1.8	15.3	18.0	53.0
	50	2.0	23.0	20.0	58.8
	60	2.0	23.0	24.0	70.6
	70	2.2	35.2	28.0	82.4
	80	2.2	35.2	32.0	94.1

訂貨： 交期： 天

OL02-05

PS. 備註

- 荷重(N)=定數(N/mm)×壓縮量(mm)
- 密著長是參考值製作時會有少許差異
- ★記號兩端皆不研磨
- 耐熱溫度80°C
- 1N=0.101972 kgf

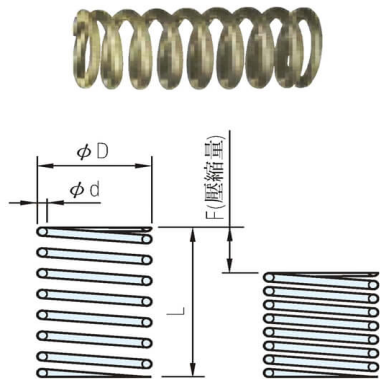

TYPE	OV	OY	OR	OF	OL	OT	OM	OH	OB
D									
2		0.05	0.2	0.3	0.5				
3	N/mm 0.05	N/mm 0.098	N/mm 0.29	N/mm 0.49	N/mm 0.98	N/mm 1.5	N/mm 2.0	N/mm 2.9	N/mm 4.9
4									
5									
6									
8									
10									
12									
13		N/mm 0.2							
14									
16									
20		0.3	0.5	0.98	2.9	3.9	4.9	14.7	29.4
F MAX	F=LX70 %	F=LX75 %	F=LX60 %	F=LX45 %	F=LX40 %	F=LX40 %	F=LX35 %	F=LX30 %	F=LX25 %

D		L	
≤10	≥12	≤50	≥55
+0	+0	±1.5	±2.5
-0.5	-0.8		

■ OM:Fmax(容許壓縮量)=LXFa %

材質	顏色
SUS304	本色

品號	D-L	d	密著長	F	荷重	Fa	單價
TYPE	D-L	d	mm	max	N/max	%	
OM	04-05*	0.4	2.2	1.75	3.4	35	•
	10*	0.5	4.9	3.5	6.8		
	15	0.55	7.5	5.25	10.3		
	20	0.6	11.1	7.0	13.7		
	25	0.6	11.1	8.75	17.2		
OM	05-05*	0.45	2.25	1.75	3.4	35	•
	10*	0.5	3.13	3.5	6.8		
	15	0.65	8.45	5.25	10.3		
	20	0.65	8.45	7.0	13.7		
	25	0.7	11.9	8.75	17.2		
	30	0.7	11.9	10.5	20.6		
	35	0.75	16.5	12.25	24.0		
	40	0.8	23.2	14.0	27.5		
OM	06-05*	0.55	2.7	1.7	4.9	35	•
	10	0.7	5.6	3.5	10.8		
	15	0.75	7.4	5.2	15.7		
	20	0.75	7.4	7.0	20.6		
	25	0.85	12.8	8.7	25.5		
	30	0.85	12.8	10.5	31.4		
	35	0.9	16.7	12.2	36.3		
	40	0.9	16.8	14.0	41.2		
	45	1.0	27.8	15.8	46.1		
	50	1.0	28.0	17.5	52.0		
OM	08-10	0.85	6.4	3.5	10.8	35	•
	15	0.9	7.9	5.2	15.7		
	20	0.9	7.9	7.0	20.6		
	25	0.9	7.9	8.7	25.5		
	30	1.0	12.0	10.5	31.4		
	35	1.0	12.0	12.2	36.3		
	40	1.1	18.7	14.0	41.2		
	45	1.1	18.7	15.8	46.1		
OM	10-10	0.9	5.2	3.5	10.8	35	•
	15	1.0	7.3	5.2	15.7		
	20	1.0	7.3	7.0	20.6		

品號	D-L	d	密著長	F	荷重	Fa	單價
TYPE	D-L	d	mm	max	N/max	%	
OM	10-25	1.1	10.5	8.7	25.5	35	•
	30	1.1	10.5	10.5	31.4		
	35	1.2	15.0	12.2	36.3		
	40	1.2	15.0	14.0	41.2		
	45	1.3	21.8	15.8	46.1		
	50	1.3	21.8	17.5	52.0		
	60	1.4	30.8	21.0	61.8		
	70	1.4	30.8	24.5	72.6		
OM	13-15	1.2	8.4	5.2	15.7	35	•
	20	1.3	11.1	7.0	20.6		
	25	1.3	11.1	8.7	25.5		
	30	1.4	15.1	10.5	31.4		
	35	1.4	15.1	12.2	36.3		
	40	1.4	15.1	14.0	41.2		
	45	1.4	15.1	15.8	46.1		
	50	1.4	15.1	17.5	52.0		
	60	1.6	27.2	21.0	61.8		
	70	1.6	27.2	24.5	72.6		
OM	16-15	1.4	9.6	5.2	15.7	35	•
	20	1.5	12.4	7.0	20.6		
	25	1.5	12.4	8.7	25.5		
	30	1.5	12.4	10.5	31.4		
	35	1.6	15.6	12.2	36.3		
	40	1.6	15.6	14.0	41.2		
	45	1.7	20.4	15.8	46.1		
	50	1.7	20.4	17.5	52.0		
OM	20-20	1.8	11.3	7.0	34.3	35	•
	25	1.9	13.3	8.8	43.1		
	30	1.9	13.3	10.5	52.0		
	35	2.0	16.0	12.3	59.8		
	40	2.0	16.0	14.0	68.6		
	45	2.2	23.7	15.8	77.5		
	50	2.2	23.7	17.5	86.3		
	60	2.2	23.7	21.0	103.0		
OM	70	2.4	34.8	24.5	120.6	35	•
	80	2.4	34.8	28.0	137.3		

訂貨： 交期： 天
OM04-05

PS. 備註

- 荷重(N)=定數(N/mm)×壓縮量(mm)
- 密著長是參考值 製作時會有少許差異
- ★記號兩端皆不研磨
- 耐熱溫度80°C
- 1N=0.101972 kgf

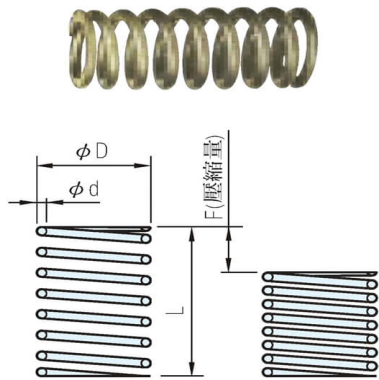

TYPE	OV	OY	OR	OF	OL	OT	OM	OH	OB
D									
2		0.05	0.2	0.3	0.5				
3									
4	N/mm 0.05	N/mm 0.098	N/mm 0.29	N/mm 0.49	N/mm 0.98	N/mm 1.5	N/mm 2.0	N/mm 2.9	N/mm 4.9
5									
6									
8									
10									
12									
13									
14		N/mm 0.2							
16									
20		0.3	0.5	0.98	2.9	3.9	4.9	14.7	29.4
F MAX	F=LX70 %	F=LX75 %	F=LX60 %	F=LX45 %	F=LX40 %	F=LX40 %	F=LX35 %	F=LX30 %	F=LX25 %

D		L	
≤ 10	≥ 12	≤ 50	≥ 55
+0	+0	± 1.5	± 2.5
-0.5	-0.8		

OH: Fmax(容許壓縮量)=LXFa %

材質	顏色
SUS304	本色

品號	d	密著長	F	荷重	Fa	單價
TYPE	D-L	mm	max	N/max	%	
OH	04-05*	0.45	2.7	1.5	4.4	30
	10*	0.5	3.8	3.0	8.8	
	15	0.6	8.1	4.5	13.2	
	20	0.65	11.7	6.0	17.6	
	30	0.7	16.8	9.0	26.5	
OH	05-05*	0.55	3.3	1.5	4.4	30
	10	0.6	4.65	3.0	8.8	
	15	0.6	4.65	4.5	13.2	
	20	0.75	11.81	6.0	17.6	
	25	0.75	11.81	7.5	22.1	
	30	0.8	16.0	9.0	26.5	
	35	0.85	21.68	10.5	30.9	
OH	06-05*	0.65	3.2	1.5	8.8	30
	10	0.7	3.9	3.0	17.7	
	15	0.85	7.7	4.5	26.5	
	20	0.9	9.7	6.0	35.3	
	25	1.0	15.5	7.5	44.1	
	30	1.0	15.5	9.0	53.0	
	35	1.1	24.8	9.8	57.9	
	40	1.1	24.8	10.0	58.8	
	45	1.1	24.8	11.3	66.7	
	50	1.2	39.0	10.0	58.8	
OH	08-10	0.9	5.3	3.0	17.7	30
	15	0.9	5.3	4.5	26.5	
	20	1.1	11.0	6.0	35.3	
	25	1.1	11.0	7.5	44.1	
	30	1.2	15.9	9.0	53.0	
	35	1.2	15.9	10.5	61.8	
	40	1.3	23.1	12.0	70.6	
	45	1.3	23.1	13.5	79.4	
	50	1.4	33.3	15.0	88.3	
	60	1.4	33.3	18.0	105.9	
OH	10-10	1.1	6.9	3.0	17.7	30
	15	1.1	6.9	4.5	26.5	
	20	1.2	9.3	6.0	35.3	
	25	1.2	9.3	7.5	44.1	

品號	d	密著長	F	荷重	Fa	單價
TYPE	D-L	mm	max	N/max	%	
OH	10-30	1.3	12.7	9.0	53.0	30
	35	1.4	17.5	10.5	61.8	
	40	1.4	17.5	12.0	70.6	
	45	1.5	23.8	13.5	79.4	
	50	1.5	23.8	15.0	88.3	
	60	1.6	32.4	18.0	105.9	
	70	1.7	44.2	21.0	123.6	
OH	13-15	1.5	9.2	4.5	44.1	30
	20	1.5	9.2	6.0	58.8	
	25	1.5	9.2	7.5	73.5	
	30	1.8	18.0	9.0	88.3	
	35	1.8	18.0	10.5	103.0	
	40	1.8	18.0	12.0	117.7	
	45	1.8	18.0	13.5	132.4	
	50	2.0	28.5	15.0	147.0	
	60	2.1	36.0	18.0	176.5	
	70	2.2	45.1	21.0	205.9	
OH	16-15	1.7	9.6	4.6	44.1	30
	20	1.9	14.0	6.0	58.8	
	25	1.9	14.0	7.5	73.5	
	30	1.9	14.0	9.0	88.3	
	35	1.9	14.0	10.5	103.0	
	40	2.2	25.1	12.0	117.7	
	45	2.2	25.1	13.5	132.4	
	50	2.2	25.1	15.0	147.1	
	60	2.3	30.5	18.0	176.5	
	70	2.5	44.7	21.0	205.9	
OH	20-25	2.3	13.8	7.5	110.8	30
	30	2.3	13.8	9.0	132.4	
	35	2.5	18.8	10.5	154.9	
	40	2.5	18.8	12.0	176.5	
	45	2.8	29.4	13.5	199.1	
	50	2.8	29.4	15.0	220.6	
	60	3.0	40.5	18.0	264.8	
	70	3.0	40.5	21.0	308.9	
	80	3.2	54.4	24.0	353.0	

PS 備註

- 荷重(N)=定數(N/mm)×壓縮量(mm)
- 密著長是參考值,製作時會有少許差異
- ★記號兩端皆不研磨
- 耐熱溫度80°C
- 1N=0.101972 kgf

訂貨: 交期:

OH04-05

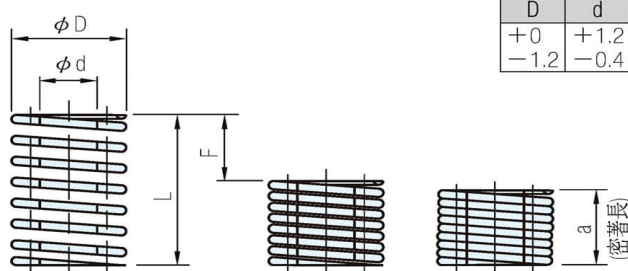

D	d	荷重	直角度	自由長	
+0	+1.2	±10%	±2°	≤50	≥55
-1.2	-0.4			±0.5	±2%

材質	顏色
SWOSC-V	銀

品號		D	d	L	定數	a	F=L×40%		F=L×45%		F=L×50%		單價
TYPE	D - L	外徑 mm	內徑 mm	自由長 mm	N/mm	密著長 mm	壓縮量 mm	荷重 N	壓縮量 mm	荷重 N	壓縮量 mm	荷重 N	
TR	14.5-020	14.5	9	20	10.90	8	8	88.3	9.0	98.1	10.0	107.9	•
	025			25	8.72	10	10		11.3		12.5		•
	030			30	7.27	12	12		13.5		15.0		•
	035			35	6.23	14	14		15.8		17.5		•
	040			40	5.45	16	16		18.0		20.0		•
	045			45	4.84	18	18		20.3		22.5		•
	050			50	4.36	20	20		22.5		25.0		•
	055			55	3.96	22	22		24.8		27.5		•
	060			60	3.63	24	24		27.0		30.0		•
	065			65	3.35	26	26		29.3		32.5		•
	070			70	3.11	28	28		31.5		35.0		•
	075			75	2.91	30	30		33.8		37.5		•
	080			80	2.73	32	32		36.0		40.0		•
	090			90	2.42	36	36		40.5		45.0		•
100	100	2.18	40	40	45.0	50.0	•						
125	125	1.74	50	50	56.3	62.5	•						
TR	17-025	17	11	25	14.82	10	10	147.1	11.3	166.7	12.5	186.3	•
	030			30	12.35	12	12		13.5		15.0		•
	035			35	10.58	14	14		15.8		17.5		•
	040			40	9.26	16	16		18.0		20.0		•
	045			45	8.23	18	18		20.3		22.5		•
	050			50	7.41	20	20		22.5		25.0		•
	055			55	6.74	22	22		24.8		27.5		•
	060			60	6.17	24	24		27.0		30.0		•
	065			65	5.70	26	26		29.3		32.5		•
	070			70	5.29	28	28		31.5		35.0		•
	075			75	4.94	30	30		33.8		37.5		•
	080			80	4.63	32	32		36.0		40.0		•
	090			90	4.12	36	36		40.5		45.0		•
	100			100	3.70	40	40		45.0		50.0		•
125	125	2.96	50	50	56.3	62.5	•						
150	150	2.47	60	60	67.5	75.0	•						
TR	21-030	21	13	30	13.80	12	12	166.7	13.5	186.3	15.0	205.9	•
	035			35	11.83	14	14		15.8		17.5		•
	040			40	10.35	16	16		18.0		20.0		•
	045			45	9.20	18	18		20.3		22.5		•
	050			50	8.28	20	20		22.5		25.0		•
	055			55	7.53	22	22		24.8		27.5		•
	060			60	6.90	24	24		27.0		30.0		•
	065			65	6.37	26	26		29.3		32.5		•
	070			70	5.91	28	28		31.5		35.0		•
	075			75	5.52	30	30		33.8		37.5		•
	080			80	5.18	32	32		36.0		40.0		•
	090			90	4.60	36	36		40.5		45.0		•
	100			100	4.14	40	40		45.0		50.0		•
	125			125	3.31	50	50		56.3		62.5		•
150	150	2.76	60	60	67.5	75.0	•						
使用回數							100萬回	50萬回	30萬回				

品 號		D	d	L	定數	a	F=L×40%		F=L×45%		F=L×50%		單 價
TYPE	D - L	外徑	內徑	自由長	N/mm	密著長	壓縮量	荷重	壓縮量	荷重	壓縮量	荷重	
		mm	mm	mm		mm	mm	N	mm	N	mm	N	
TR	26-030	26	16.5	30	26.87	12	12	323.6	13.5	362.8	15.0	402.1	•
	035			35	23.03	14	14		15.8		17.5		•
	040			40	20.16	16	16		18.0		20.0		•
	045			45	17.92	18	18		20.3		22.5		•
	050			50	16.12	20	20		22.5		25.0		•
	055			55	14.66	22	22		24.8		27.5		•
	060			60	13.44	24	24		27.0		30.0		•
	065			65	12.40	26	26		29.3		32.5		•
	070			70	11.52	28	28		31.5		35.0		•
	075			75	10.75	30	30		33.8		37.5		•
	080			80	10.08	32	32		36.0		40.0		•
	090			90	8.96	36	36		40.5		45.0		•
	100			100	8.06	40	40		45.0		50.0		•
	110			110	7.33	44	44		49.5		55.0		•
	125			125	6.45	50	50		56.3		62.5		•
	150			150	5.37	60	60		67.5		75.0		•
	175			175	4.61	70	70		78.8		87.5		•
200	200	4.03	80	80	90.0	100.0	•						
TR	32-040	32	21	40	25.06	16	16	402.1	18.0	451.1	20.0	500.1	•
	045			45	22.28	18	18		20.3		22.5		•
	050			50	20.05	20	20		22.5		25.0		•
	060			60	16.71	24	24		27.0		30.0		•
	070			70	14.32	28	28		31.5		35.0		•
	080			80	12.53	32	32		36.0		40.0		•
	090			90	11.14	36	36		40.5		45.0		•
	100			100	10.02	40	40		45.0		50.0		•
	110			110	9.11	44	44		49.5		55.0		•
	125			125	8.02	50	50		56.3		62.5		•
	150			150	6.68	60	60		67.5		75.0		•
	175			175	5.73	70	70		78.8		87.5		•
	200			200	5.01	80	80		90.0		100.0		•
	250			250	4.01	100	100		112.5		125.0		•
300	300	3.34	120	120	135.0	150.0	•						
TR	39-040	39	26	40	27.24	16	16	431.5	18.0	490.3	20.0	539.4	•
	045			45	24.21	18	18		20.3		22.5		•
	050			50	21.79	20	20		22.5		25.0		•
	060			60	18.16	24	24		27.0		30.0		•
	070			70	15.57	28	28		31.5		35.0		•
	080			80	13.62	32	32		36.0		40.0		•
	090			90	12.11	36	36		40.5		45.0		•
	100			100	10.90	40	40		45.0		50.0		•
	110			110	9.91	44	44		49.5		55.0		•
	125			125	8.72	50	50		56.3		62.5		•
	150			150	7.26	60	60		67.5		75.0		•
	175			175	6.23	70	70		78.8		87.5		•
	200			200	5.45	80	80		90.0		100.0		•
	250			250	4.36	100	100		112.5		125.0		•
300	300	3.63	120	120	135.0	150.0	•						
TR	46-050	46	32	50	24.41	20	20	490.3	22.5	549.2	25.0	608.0	•
	060			60	20.34	24	24		27.0		30.0		•
	070			70	17.43	28	28		31.5		35.0		•
	080			80	15.26	32	32		36.0		40.0		•
	090			90	13.56	36	36		40.5		45.0		•
	100			100	12.20	40	40		45.0		50.0		•
	110			110	11.09	44	44		49.5		55.0		•
	125			125	9.76	50	50		56.3		62.5		•
	150			150	8.14	60	60		67.5		75.0		•
	175			175	6.97	70	70		78.8		87.5		•
	200			200	6.10	80	80		90.0		100.0		•
	250			250	4.88	100	100		112.5		125.0		•
300	300	4.07	120	120	135.0	150.0	•						
使用回數							100萬回	50萬回	30萬回				

PS. 備註

- 荷重(N)=定數(N/mm)×壓縮量(mm)
- 密著長是參考值,製作時會有少許差異
- 耐熱溫度200°C,最適合塑膠模使用
- 1N=0.101972 kgf

訂貨: 交期:

TR26-030

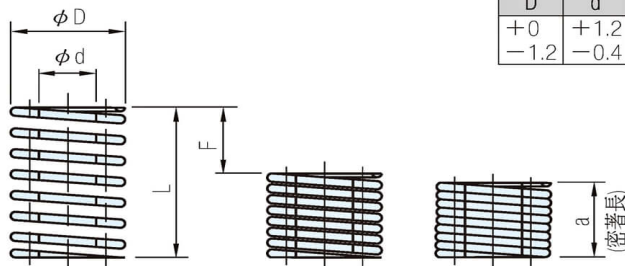

D	d	荷重	直角度	自由長	
+0	+1.2	±10%	±2°	≤50	≥55
-1.2	-0.4			±0.5	±2%

材質	顏色
SWOSC-V	紫

品號		D	d	L	定數	a	F=L×40%		F=L×45%		F=L×50%		單價
TYPE	D - L	外徑 mm	內徑 mm	自由長 mm	N/mm	密著長 mm	壓縮量 mm	荷重 N	壓縮量 mm	荷重 N	壓縮量 mm	荷重 N	
TY	14.5-020	14.5	9	20	18.52	8	8	147.1	9.0	166.7	10.0	186.3	•
	025			25	14.82	10	10		11.3		12.5		
	030			30	12.35	12	12		13.5		15.0		
	035			35	10.58	14	14		15.8		17.5		
	040			40	9.26	16	16		18.0		20.0		
	045			45	8.23	18	18		20.3		22.5		
	050			50	7.41	20	20		22.5		25.0		
	055			55	6.74	22	22		24.8		27.5		
	060			60	6.17	24	24		27.0		30.0		
	065			65	5.70	26	26		29.3		32.5		
	070			70	5.29	28	28		31.5		35.0		
	075			75	4.94	30	30		33.8		37.5		
	080			80	4.63	32	32		36.0		40.0		
	090			90	4.12	36	36		40.5		45.0		
	100			100	3.70	40	40		45.0		50.0		
125	125	2.96	50	50	56.3	62.5							
TY	17-025	17	11	25	21.80	10	10	215.7	11.3	245.2	12.5	274.6	•
	030			30	18.16	12	12		13.5		15.0		
	035			35	15.57	14	14		15.8		17.5		
	040			40	13.62	16	16		18.0		20.0		
	045			45	12.11	18	18		20.3		22.5		
	050			50	10.90	20	20		22.5		25.0		
	055			55	9.91	22	22		24.8		27.5		
	060			60	9.08	24	24		27.0		30.0		
	065			65	8.38	26	26		29.3		32.5		
	070			70	7.78	28	28		31.5		35.0		
	075			75	7.27	30	30		33.8		37.5		
	080			80	6.81	32	32		36.0		40.0		
	090			90	6.05	36	36		40.5		45.0		
	100			100	5.45	40	40		45.0		50.0		
	125			125	4.36	50	50		56.3		62.5		
150	150	3.63	60	60	67.5	75.0							
TY	21-030	21	13	30	23.24	12	12	284.4	13.5	313.8	15.0	353.0	•
	035			35	19.92	14	14		15.8		17.5		
	040			40	17.43	16	16		18.0		20.0		
	045			45	15.50	18	18		20.3		22.5		
	050			50	13.95	20	20		22.5		25.0		
	055			55	12.68	22	22		24.8		27.5		
	060			60	11.62	24	24		27.0		30.0		
	065			65	10.73	26	26		29.3		32.5		
	070			70	9.96	28	28		31.5		35.0		
	075			75	9.30	30	30		33.8		37.5		
	080			80	8.72	32	32		36.0		40.0		
	090			90	7.75	36	36		40.5		45.0		
	100			100	6.97	40	40		45.0		50.0		
	125			125	5.58	50	50		56.3		62.5		
	150			150	4.65	60	60		67.5		75.0		
使用回數							100萬回	50萬回	30萬回				

品號		D	d	L	定數	a	F=L×40%		F=L×45%		F=L×50%		單價
TYPE	D - L	外徑 mm	內徑 mm	自由長 mm	N/mm	密著長 mm	壓縮量 mm	荷重 N	壓縮量 mm	荷重 N	壓縮量 mm	荷重 N	
TY	26-030	26	16.5	30	34.87	12	12	411.9	13.5	470.7	15.0	519.8	•
	035			35	29.89	14	14		15.8		17.5		
	040			40	26.15	16	16		18.0		20.0		
	045			45	23.24	18	18		20.3		22.5		
	050			50	20.92	20	20		22.5		25.0		
	055			55	19.02	22	22		24.8		27.5		
	060			60	17.43	24	24		27.0		30.0		
	065			65	16.09	26	26		29.3		32.5		
	070			70	14.94	28	28		31.5		35.0		
	075			75	13.95	30	30		33.8		37.5		
	080			80	13.08	32	32		36.0		40.0		
	090			90	11.62	36	36		40.5		45.0		
	100			100	10.46	40	40		45.0		50.0		
	110			110	9.51	44	44		49.5		55.0		
	125			125	8.37	50	50		56.3		62.5		
	150			150	6.97	60	60		67.5		75.0		
175	175	5.98	70	70	78.8	87.5							
200	200	5.23	80	80	90.0	100.0							
TY	32-040	32	21	40	34.87	16	16	559.0	18.0	627.6	20.0	696.3	•
	045			45	30.99	18	18		20.3		22.5		
	050			50	27.89	20	20		22.5		25.0		
	060			60	23.24	24	24		27.0		30.0		
	070			70	19.92	28	28		31.5		35.0		
	080			80	17.43	32	32		36.0		40.0		
	090			90	15.50	36	36		40.5		45.0		
	100			100	13.95	40	40		45.0		50.0		
	110			110	12.68	44	44		49.5		55.0		
	125			125	11.16	50	50		56.3		62.5		
	150			150	9.30	60	60		67.5		75.0		
	175			175	9.97	70	70		78.8		87.5		
	200			200	6.97	80	80		90.0		100.0		
	250			250	5.58	100	100		112.5		125.0		
	300			300	4.65	120	120		135.0		150.0		
	TY			39-040	39	26	40		45.77		16		16
045		45	40.68	18			18	20.3	22.5				
050		50	36.61	20			20	22.5	25.0				
060		60	30.51	24			24	27.0	30.0				
070		70	26.15	28			28	31.5	35.0				
080		80	22.88	32			32	36.0	40.0				
090		90	20.34	36			36	40.5	45.0				
100		100	18.31	40			40	45.0	50.0				
110		110	16.64	44			44	49.5	55.0				
125		125	14.65	50			50	56.3	62.5				
150		150	12.20	60			60	67.5	75.0				
175		175	10.46	70			70	78.8	87.5				
200		200	9.15	80			80	90.0	100.0				
250		250	7.32	100			100	112.5	125.0				
300		300	6.10	120			120	135.0	150.0				
TY		46-050	46	32			50	48.81	20	20	970.9	22.5	1098
	060	60			40.68	24	24	27.0	30.0				
	070	70			34.87	28	28	31.5	35.0				
	080	80			30.51	32	32	36.0	40.0				
	090	90			27.12	36	36	40.5	45.0				
	100	100			24.41	40	40	45.0	50.0				
	110	110			22.19	44	44	49.5	55.0				
	125	125			19.53	50	50	56.3	62.5				
	150	150			16.27	60	60	67.5	75.0				
	175	175			13.95	70	70	78.8	87.5				
	200	200			12.20	80	80	90.0	100.0				
	250	250			9.76	100	100	112.5	125.0				
300	300	8.14	120	120	135.0	150.0							

使用回數

100萬回

50萬回

30萬回

PS. 備註

- 荷重(N)=定數(N/mm)×壓縮量(mm)
- 密著長是參考值 製作時會有少許差異
- 耐熱溫度200°C,最適合塑膠模使用
- 1N=0.101972 kgf

訂貨： 交期：

TY26-030

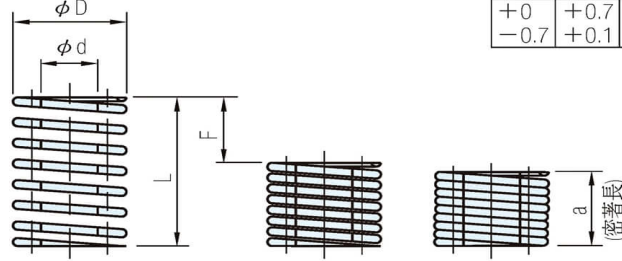

D	d	荷重	直角度	自由長	
+0	+0.7	±10%	±2°	≤50	≥55
-0.7	+0.1			±0.5	±1%

材質	顏色
SWOSC-V	黃

品號		D	d	L	定數	a	F=L×40%		F=L×45%		F=L×50%		單價
TYPE	D - L	外徑 mm	內徑 mm	自由長 mm	N/mm	密著長 mm	壓縮量 mm	荷重 N	壓縮量 mm	荷重 N	壓縮量 mm	荷重 N	
TF	08-010	8	4	10	15.24	4.5	4	58.8	4.5	68.6	5.0	78.5	•
	015			15	10.16	6.8	6		6.8		7.5		•
	020			20	7.62	9.0	8		9.0		10.0		•
	025			25	6.10	11.3	10		11.3		12.5		•
	030			30	5.08	13.5	12		13.5		15.0		•
	035			35	4.36	15.8	14		15.8		17.5		•
	040			40	3.81	18.0	16		18.0		20.0		•
	045			45	3.39	20.3	18		20.3		22.5		•
	050			50	3.05	22.5	20		22.5		25.0		•
	055			55	2.77	24.8	22		24.8		27.5		•
	060			60	2.54	27.0	24		27.0		30.0		•
	065			65	2.35	29.3	26		29.3		32.5		•
	070			70	2.18	31.5	28		31.5		35.0		•
075	75	2.03	33.8	30	33.8	37.5	•						
080	80	1.91	36.0	32	36.0	40.0	•						
TF	10-020	10	5	20	9.81	9.0	8	78.5	9.0	88.3	10.0	98.1	•
	025			25	7.85	11.3	10		11.3		12.5		•
	030			30	6.54	13.5	12		13.5		15.0		•
	035			35	5.61	15.8	14		15.8		17.5		•
	040			40	4.91	18.0	16		18.0		20.0		•
	045			45	4.36	20.3	18		20.3		22.5		•
	050			50	3.92	22.5	20		22.5		25.0		•
	055			55	3.57	24.8	22		24.8		27.5		•
	060			60	3.27	27.0	24		27.0		30.0		•
	065			65	3.02	29.3	26		29.3		32.5		•
	070			70	2.80	31.5	28		31.5		35.0		•
	075			75	2.62	33.8	30		33.8		37.5		•
	080			80	2.45	36.0	32		36.0		40.0		•
090	90	2.18	40.5	36	40.5	45.0	•						
TF	12-020	12	6	20	13.62	9.0	8	107.9	9.0	122.6	10.0	137.3	•
	025			25	10.90	11.3	10		11.3		12.5		•
	030			30	9.08	13.5	12		13.5		15.0		•
	035			35	7.78	15.8	14		15.8		17.5		•
	040			40	6.81	18.0	16		18.0		20.0		•
	045			45	6.05	20.3	18		20.3		22.5		•
	050			50	5.45	22.5	20		22.5		25.0		•
	055			55	4.95	24.8	22		24.8		27.5		•
	060			60	4.54	27.0	24		27.0		30.0		•
	065			65	4.19	29.3	26		29.3		32.5		•
	070			70	3.89	31.5	28		31.5		35.0		•
	075			75	3.63	33.8	30		33.8		37.5		•
	080			80	3.41	36.0	32		36.0		40.0		•
090	90	3.03	40.5	36	40.5	45.0	•						
TF	14-025	14	7	25	13.95	11.3	10	142.2	11.3	156.9	12.5	176.5	•
	030			30	11.62	13.5	12		13.5		15.0		•
	035			35	9.96	15.8	14		15.8		17.5		•
	040			40	8.72	18.0	16		18.0		20.0		•
使用回數							100萬回	50萬回	30萬回				

品 號		D	d	L	定數	a	F=L×40%		F=L×45%		F=L×50%		單 價
TYPE	D - L	外徑 mm	內徑 mm	自由長 mm	N/mm	密著長 mm	壓縮量 mm	荷重 N	壓縮量 mm	荷重 N	壓縮量 mm	荷重 N	
TF	14-045	14	7	45	7.75	20.3	18	142.2	20.3	156.9	22.5	176.5	•
	050			50	6.97	22.5	20		22.5		25.0		•
	055			55	6.34	24.8	22		24.8		27.5		•
	060			60	5.81	27.0	24		27.0		30.0		•
	065			65	5.36	29.3	26		29.3		32.5		•
	070			70	4.98	31.5	28		31.5		35.0		•
	075			75	4.65	33.8	30		33.8		37.5		•
	080			80	4.36	36.0	32		36.0		40.0		•
	090			90	3.87	40.5	36		40.5		45.0		•
	100			100	3.49	45.0	40		45.0		50.0		•
TF	16-025	16	8	25	16.56	11.3	10	166.7	11.3	186.3	12.5	206	•
	030			30	13.80	13.5	12		13.5		15.0		•
	035			35	11.83	15.8	14		15.8		17.5		•
	040			40	10.35	18.0	16		18.0		20.0		•
	045			45	9.20	20.3	18		20.3		22.5		•
	050			50	8.28	22.5	20		22.5		25.0		•
	055			55	7.53	24.8	22		24.8		27.5		•
	060			60	6.90	27.0	24		27.0		30.0		•
	065			65	6.37	29.3	26		29.3		32.5		•
	070			70	5.91	31.5	28		31.5		35.0		•
	075			75	5.52	33.8	30		33.8		37.5		•
	080			80	5.18	36.0	32		36.0		40.0		•
	090			90	4.60	40.5	36		40.5		45.0		•
	100			100	4.14	45.0	40		45.0		50.0		•
	125			125	3.31	56.3	50		56.3		62.5		•
TF	18-025	18	9	25	20.09	11.3	10	206	11.3	226	12.5	255	•
	030			30	16.74	13.5	12		13.5		15.0		•
	035			35	14.35	15.8	14		15.8		17.5		•
	040			40	12.56	18.0	16		18.0		20.0		•
	045			45	11.16	20.3	18		20.3		22.5		•
	050			50	10.04	22.5	20		22.5		25.0		•
	055			55	9.13	24.8	22		24.8		27.5		•
	060			60	8.37	27.0	24		27.0		30.0		•
	065			65	7.73	29.3	26		29.3		32.5		•
	070			70	7.17	31.5	28		31.5		35.0		•
	075			75	6.70	33.8	30		33.8		37.5		•
	080			80	6.28	36.0	32		36.0		40.0		•
	090			90	5.58	40.5	36		40.5		45.0		•
	100			100	5.02	45.0	40		45.0		50.0		•
	125			125	4.02	56.3	50		56.3		62.5		•
TF	20-025	20	11	25	25.24	11.3	10	255	11.3	284	12.5	314	•
	030			30	21.04	13.5	12		13.5		15.0		•
	035			35	18.03	15.8	14		15.8		17.5		•
	040			40	15.78	18.0	16		18.0		20.0		•
	045			45	14.02	20.3	18		20.3		22.5		•
	050			50	12.62	22.5	20		22.5		25.0		•
	055			55	11.47	24.8	22		24.8		27.5		•
	060			60	10.52	27.0	24		27.0		30.0		•
	065			65	9.71	29.3	26		29.3		32.5		•
	070			70	9.02	31.5	28		31.5		35.0		•
	075			75	8.41	33.8	30		33.8		37.5		•
	080			80	7.89	36.0	32		36.0		40.0		•
	090			90	7.01	40.5	36		40.5		45.0		•
	100			100	6.31	45.0	40		45.0		50.0		•
	125			125	5.05	56.3	50		56.3		62.5		•
150	150	4.21	67.5	60	67.5	75.0	•						
使用回數							100萬回	50萬回	30萬回				

PS. 備註

- 荷重(N)=定數(N/mm)×壓縮量(mm)
- 密著長是參考值,製作時會有少許差異
- 耐熱溫度150°C
- 彈簧導銷請參考本單元 RG,PGC,PGA
- 1N=0.101972kgf

訂貨: 交期:

TF08-010

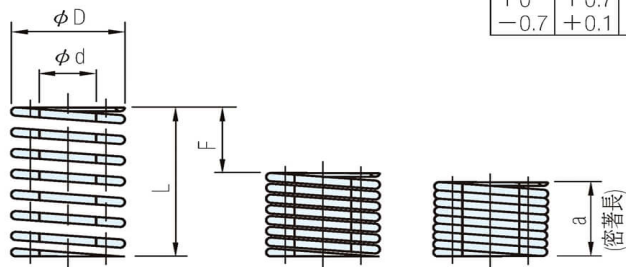

D	d	荷重	直角度	自由長	
+0	+0.7	±10%	±2°	≤50	≥55
-0.7	+0.1			±0.5	±1%

材質	顏色
SWOSC-V	藍

品號		D	d	L	定數	a	F=L×32%		F=L×36%		F=L×40%		單價
TYPE	D - L	外徑 mm	內徑 mm	自由長 mm	N/mm	密著長 mm	壓縮量 mm	荷重 N	壓縮量 mm	荷重 N	壓縮量 mm	荷重 N	
TL	08-010	8	4	10	24.53	5.4	3.2	78.5	3.6	88.3	4.0	98.1	•
	015			15	16.35	8.1	4.8		5.4		6.0		•
	020			20	12.26	10.8	6.4		7.2		8.0		•
	025			25	9.81	13.5	8.0		9.0		10.0		•
	030			30	8.18	16.2	9.6		10.8		12.0		•
	035			35	7.01	18.9	11.2		12.6		14.0		•
	040			40	6.13	21.6	12.8		14.4		16.0		•
	045			45	5.45	24.3	14.4		16.2		18.0		•
	050			50	4.91	27.0	16.0		18.0		20.0		•
	055			55	4.46	29.7	17.6		19.8		22.0		•
	060			60	4.09	32.4	19.2		21.6		24.0		•
	065			65	3.77	35.1	20.8		23.4		26.0		•
	070			70	3.50	37.8	22.4		25.2		28.0		•
	075			75	3.27	40.5	24.0		27.0		30.0		•
080	80	3.07	43.2	25.6	28.8	32.0	•						
TL	10-020	10	5	20	17.71	10.8	6.4	112.8	7.2	127.5	8.0	142.2	•
	025			25	14.17	13.5	8.0		9.0		10.0		•
	030			30	11.81	16.2	9.6		10.8		12.0		•
	035			35	10.12	18.9	11.2		12.6		14.0		•
	040			40	8.85	21.6	12.8		14.4		16.0		•
	045			45	7.87	24.3	14.4		16.2		18.0		•
	050			50	7.08	27.0	16.0		18.0		20.0		•
	055			55	6.44	29.7	17.6		19.8		22.0		•
	060			60	5.90	32.4	19.2		21.6		24.0		•
	065			65	5.45	35.1	20.8		23.4		26.0		•
	070			70	5.06	37.8	22.4		25.2		28.0		•
	075			75	4.72	40.5	24.0		27.0		30.0		•
	080			80	4.43	43.2	25.6		28.8		32.0		•
	090			90	3.94	48.6	28.8		32.4		36.0		•
TL	12-020	12	6	20	25.88	10.8	6.4	166.7	7.2	186.3	8.0	206.0	•
	025			25	20.70	13.5	8.0		9.0		10.0		•
	030			30	17.25	16.2	9.6		10.8		12.0		•
	035			35	14.79	18.9	11.2		12.6		14.0		•
	040			40	12.94	21.6	12.8		14.4		16.0		•
	045			45	11.50	24.3	14.4		16.2		18.0		•
	050			50	10.35	27.0	16.0		18.0		20.0		•
	055			55	9.41	29.7	17.6		19.8		22.0		•
	060			60	8.63	32.4	19.2		21.6		24.0		•
	065			65	7.96	35.1	20.8		23.4		26.0		•
	070			70	7.39	37.8	22.4		25.2		28.0		•
	075			75	6.90	40.5	24.0		27.0		30.0		•
	080			80	6.47	43.2	25.6		28.8		32.0		•
	090			90	5.75	48.6	28.8		32.4		36.0		•
TL	14-025	14	7	25	27.22	13.5	8.0	216	9.0	245	10.0	275	•
	030			30	22.69	16.2	9.6		10.8		12.0		•
	035			35	19.44	18.9	11.2		12.6		14.0		•
	040			40	17.01	21.6	12.8		14.4		16.0		•
	045			45	15.12	24.3	14.4		16.2		18.0		•
	050			50	13.61	27.0	16.0		18.0		20.0		•
	055			55	12.37	29.7	17.6		19.8		22.0		•
使用回數							100萬回	50萬回	30萬回				

品號		D	d	L	定數	a	F=L×32%		F=L×36%		F=L×40%		單價
TYPE	D - L	外徑 mm	內徑 mm	自由長 mm	N/mm	密著長 mm	壓縮量 mm	荷重 N	壓縮量 mm	荷重 N	壓縮量 mm	荷重 N	
TL	14-060	14	7	60	11.34	32.4	19.2	216	21.6	245	24.0	275	•
	065			65	10.47	35.1	20.8		23.4		26.0		•
	070			70	9.72	37.8	22.4		25.2		28.0		•
	075			75	9.07	40.5	24.0		27.0		30.0		•
	080			80	8.51	43.2	25.6		28.8		32.0		•
	090			90	7.56	48.6	28.8		32.4		36.0		•
	100			100	6.81	54.0	32.0		36.0		40.0		•
TL	16-025	16	8	25	34.89	13.5	8.0	275	9.0	314	10.0	343	•
	030			30	29.07	16.2	9.6		10.8		12.0		•
	035			35	24.92	18.9	11.2		12.6		14.0		•
	040			40	21.81	21.6	12.8		14.4		16.0		•
	045			45	19.38	24.3	14.4		16.2		18.0		•
	050			50	17.44	27.0	16.0		18.0		20.0		•
	055			55	15.86	29.7	17.6		19.8		22.0		•
	060			60	14.54	32.4	19.2		21.6		24.0		•
	065			65	13.42	35.1	20.8		23.4		26.0		•
	070			70	12.46	37.8	22.4		25.2		28.0		•
	075			75	11.63	40.5	24.0		27.0		30.0		•
	080			80	10.90	43.2	25.6		28.8		32.0		•
	090			90	9.69	48.6	28.8		32.4		36.0		•
	100			100	8.72	54.0	32.0		36.0		40.0		•
125	125	6.98	67.5	40.0	45.0	50.0	•						
TL	18-025	18	9	25	42.44	13.5	8.0	333	9.0	382	10.0	422	•
	030			30	35.37	16.2	9.6		10.8		12.0		•
	035			35	30.32	18.9	11.2		12.6		14.0		•
	040			40	26.53	21.6	12.8		14.4		16.0		•
	045			45	23.58	24.3	14.4		16.2		18.0		•
	050			50	21.22	27.0	16.0		18.0		20.0		•
	055			55	19.29	29.7	17.6		19.8		22.0		•
	060			60	17.69	32.4	19.2		21.6		24.0		•
	065			65	16.32	35.1	20.8		23.4		26.0		•
	070			70	15.16	37.8	22.4		25.2		28.0		•
	075			75	14.15	40.5	24.0		27.0		30.0		•
	080			80	13.26	43.2	25.6		28.8		32.0		•
	090			90	11.79	48.6	28.8		32.4		36.0		•
	100			100	10.61	54.0	32.0		36.0		40.0		•
125	125	8.49	67.5	40.0	45.0	50.0	•						
TL	20-025	20	10	25	53.44	13.5	8.0	422	9.0	481	10.0	530	•
	030			30	44.54	16.2	9.6		10.8		12.0		•
	035			35	38.17	18.9	11.2		12.6		14.0		•
	040			40	33.40	21.6	12.8		14.4		16.0		•
	045			45	29.69	24.3	14.4		16.2		18.0		•
	050			50	26.72	27.0	16.0		18.0		20.0		•
	055			55	24.29	29.7	17.6		19.8		22.0		•
	060			60	22.27	32.4	19.2		21.6		24.0		•
	065			65	20.56	35.1	20.8		23.4		26.0		•
	070			70	19.09	37.8	22.4		25.2		28.0		•
	075			75	17.81	40.5	24.0		27.0		30.0		•
	080			80	16.70	43.2	25.6		28.8		32.0		•
	090			90	14.85	48.6	28.8		32.4		36.0		•
	100			100	13.36	54.0	32.0		36.0		40.0		•
125	125	10.69	67.5	40.0	45.0	50.0	•						
150	150	8.91	81.0	48.0	54.0	60.0	•						
TL	22-025	22	11	25	65.33	13.5	8.0	530	9.0	588	10.0	657	•
	030			30	54.44	16.2	9.6		10.8		12.0		•
	035			35	46.67	18.9	11.2		12.6		14.0		•
	040			40	40.83	21.6	12.8		14.4		16.0		•
	045			45	36.30	24.3	14.4		16.2		18.0		•
	050			50	32.67	27.0	16.0		18.0		20.0		•
	055			55	29.70	29.7	17.6		19.8		22.0		•
	060			60	27.22	32.4	19.2		21.6		24.0		•

使用回數

100萬回

50萬回

30萬回

PS. 備註

- 荷重(N)=定數(N/mm)×壓縮量(mm)
- 密著長是參考值 製作時會有少許差異
- 耐熱溫度150°C
- 1N=0.101972kgf

訂貨： 交期： 天

TL14-060

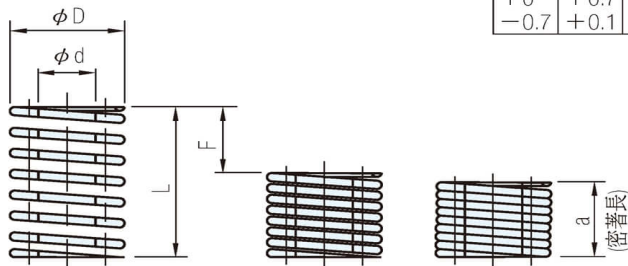

D	d	荷重	直角度	自由長	
+0	+0.7	±10%	±2°	≤50	≥55
-0.7	+0.1			±0.5	±1%

材質	顏色
SWOSC-V	紅

品號		D	d	L	定數	a	F=L×25.6%	F=L×28.8%	F=L×32%	單價			
TYPE	D - L	外徑 mm	內徑 mm	自由長 mm	N/mm	密著長 mm	壓縮量 mm	荷重 N	壓縮量 mm		荷重 N	壓縮量 mm	荷重 N
TM	08-010	8	4	10	42.57	6.3	2.6	108	2.9	123	3.2	137	•
	015			15	28.38	9.4	3.8		4.3		4.8		•
	020			20	21.28	12.5	5.1		5.8		6.4		•
	025			25	17.03	15.7	6.4		7.2		8.0		•
	030			30	14.19	18.8	7.7		8.6		9.6		•
	035			35	12.16	21.9	9.0		10.1		11.2		•
	040			40	10.64	25.0	10.2		11.5		12.8		•
	045			45	9.46	28.2	11.5		13.0		14.4		•
	050			50	8.51	31.3	12.8		14.4		16.0		•
	055			55	7.74	34.4	14.1		15.8		17.6		•
	060			60	7.09	37.6	15.4		17.3		19.2		•
	065			65	6.55	40.7	16.6		18.7		20.8		•
	070			70	6.08	43.8	17.9		20.2		22.4		•
	075			75	5.68	47.0	19.2		21.6		24.0		•
080	80	5.32	50.1	20.5	23.0	25.6	•						
TM	10-020	10	5	20	30.64	12.5	5.1	157	5.8	177	6.4	196	•
	025			25	24.51	15.7	6.4		7.2		8.0		•
	030			30	20.43	18.8	7.7		8.6		9.6		•
	035			35	17.51	21.9	9.0		10.1		11.2		•
	040			40	15.32	25.0	10.2		11.5		12.8		•
	045			45	13.62	28.2	11.5		13.0		14.4		•
	050			50	12.26	31.3	12.8		14.4		16.0		•
	055			55	11.14	34.4	14.1		15.8		17.6		•
	060			60	10.21	37.6	15.4		17.3		19.2		•
	065			65	9.43	40.7	16.6		18.7		20.8		•
	070			70	8.75	43.8	17.9		20.2		22.4		•
	075			75	8.17	47.0	19.2		21.6		24.0		•
	080			80	7.66	50.1	20.5		23.0		25.6		•
	090			90	6.81	56.3	23.0		25.9		28.8		•
TM	12-020	12	6	20	44.27	12.5	5.1	226	5.8	255	6.4	284	•
	025			25	35.42	15.7	6.4		7.2		8.0		•
	030			30	29.51	18.8	7.7		8.6		9.6		•
	035			35	25.30	21.9	9.0		10.1		11.2		•
	040			40	22.14	25.0	10.2		11.5		12.8		•
	045			45	19.68	28.2	11.5		13.0		14.4		•
	050			50	17.71	31.3	12.8		14.4		16.0		•
	055			55	16.10	34.4	14.1		15.8		17.6		•
	060			60	14.76	37.6	15.4		17.3		19.2		•
	065			65	13.62	40.7	16.6		18.7		20.8		•
	070			70	12.65	43.8	17.9		20.2		22.4		•
	075			75	11.81	47.0	19.2		21.6		24.0		•
	080			80	11.07	50.1	20.5		23.0		25.6		•
	090			90	9.84	56.3	23.0		25.9		28.8		•
TM	14-025	14	7	25	47.64	15.7	6.4	304	7.2	343	8.0	383	•
	030			30	39.70	18.8	7.7		8.6		9.6		•
	035			35	34.03	21.9	9.0		10.1		11.2		•
	040			40	29.77	25.0	10.2		11.5		12.8		•
	045			45	26.47	28.2	11.5		13.0		14.4		•
使用回數							100萬回	50萬回	30萬回				

品號		D	d	L	定數	a	F=L×25.6%		F=L×28.8%		F=L×32%		單價
TYPE	D - L	外徑	內徑	自由長	N/mm	密著長	壓縮量	荷重	壓縮量	荷重	壓縮量	荷重	
		mm	mm	mm		mm	mm	N	mm	N	mm	N	
TM	14-050	14	7	50	23.82	31.3	12.8	304	14.4	343	16.0	383	•
	055			55	21.65	34.4	14.1		15.8		17.6		•
	060			60	19.85	37.6	15.4		17.3		19.2		•
	065			65	18.32	40.7	16.6		18.7		20.8		•
	070			70	17.01	43.8	17.9		20.2		22.4		•
	075			75	15.88	47.0	19.2		21.6		24.0		•
	080			80	14.89	50.1	20.5		23.0		25.6		•
	090			90	13.23	56.3	23.0		25.9		28.8		•
	100			100	11.91	62.6	25.6		28.8		32.0		•
TM	16-025	16	8	25	62.64	15.7	6.4	402	7.2	451	8.0	500	•
	030			30	52.20	18.8	7.7		8.6		9.6		•
	035			35	44.74	21.9	9.0		10.1		11.2		•
	040			40	39.15	25.0	10.2		11.5		12.8		•
	045			45	34.80	28.2	11.5		13.0		14.4		•
	050			50	31.32	31.3	12.8		14.4		16.0		•
	055			55	28.47	34.4	14.1		15.8		17.6		•
	060			60	26.10	37.6	15.4		17.3		19.2		•
	065			65	24.09	40.7	16.6		18.7		20.8		•
	070			70	22.37	43.8	17.9		20.2		22.4		•
	075			75	20.88	47.0	19.2		21.6		24.0		•
	080			80	19.57	50.1	20.5		23.0		25.6		•
	090			90	17.40	56.3	23.0		25.9		28.8		•
	100			100	15.66	62.6	25.6		28.8		32.0		•
	TM			18-025	18	9	25		79.03		15.7		6.4
030		30	65.86	18.8			7.7	8.6	9.6	•			
035		35	56.45	21.9			9.0	10.1	11.2	•			
040		40	49.39	25.0			10.2	11.5	12.8	•			
045		45	43.90	28.2			11.5	13.0	14.4	•			
050		50	39.51	31.3			12.8	14.4	16.0	•			
055		55	35.92	34.4			14.1	15.8	17.6	•			
060		60	32.93	37.6			15.4	17.3	19.2	•			
065		65	30.40	40.7			16.6	18.7	20.8	•			
070		70	28.22	43.8			17.9	20.2	22.4	•			
075		75	26.34	47.0			19.2	21.6	24.0	•			
080		80	24.70	50.1			20.5	23.0	25.6	•			
090		90	21.95	56.3			23.0	25.9	28.8	•			
100		100	19.76	62.6			25.6	28.8	32.0	•			
TM		20-025	20	10			25	98.06	15.7	6.4	628	7.2	706
	030	30			81.71	18.8	7.7	8.6	9.6	•			
	035	35			70.04	21.9	9.0	10.1	11.2	•			
	040	40			61.28	25.0	10.2	11.5	12.8	•			
	045	45			54.48	28.2	11.5	13.0	14.4	•			
	050	50			49.03	31.3	12.8	14.4	16.0	•			
	055	55			44.57	34.4	14.1	15.8	17.6	•			
	060	60			40.86	37.6	15.4	17.3	19.2	•			
	065	65			37.71	40.7	16.6	18.7	20.8	•			
	070	70			35.02	43.8	17.9	20.2	22.4	•			
	075	75			32.69	47.0	19.2	21.6	24.0	•			
	080	80			30.64	50.1	20.5	23.0	25.6	•			
	090	90			27.24	56.3	23.0	25.9	28.8	•			
	100	100			24.51	62.6	25.6	28.8	32.0	•			
	TM	22-025			22	11	25	118.47	15.7	6.4		765	
030		30	98.73	18.8			7.7	8.6	9.6	•			
035		35	84.62	21.9			9.0	10.1	11.2	•			
040		40	74.05	25.0			10.2	11.5	12.8	•			
045		45	65.82	28.2			11.5	13.0	14.4	•			
050		50	59.24	31.3			12.8	14.4	16.0	•			
055		55	53.85	34.4			14.1	15.8	17.6	•			
060		60	49.36	37.6			15.4	17.3	19.2	•			

使用回數 100萬回 50萬回 30萬回

訂貨： 交期： 天
TM14-050

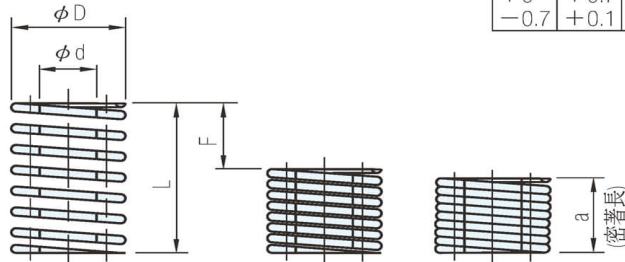

D	d	荷重	直角度	自由長	
+0 -0.7	+0.7 +0.1	±10%	±2°	≤50 ±0.5	≥55 ±1%

材質	顏色
SWOSC-V	綠

品 號		D	d	L	定數	a	F=L×19.2%		F=L×21.6%		F=L×24%		單 價
TYPE	D - L	外徑 mm	內徑 mm	自由長 mm	N/mm	密著長 mm	壓縮量 mm	荷重 N	壓縮量 mm	荷重 N	壓縮量 mm	荷重 N	
TH	08-010	8	4	10	86.25	7.2	1.9	167	2.2	186	2.4	206	•
	015			15	57.50	10.8	2.9		3.2		3.6		•
	020			20	43.13	14.4	3.8		4.3		4.8		•
	025			25	34.50	18.0	4.8		5.4		6.0		•
	030			30	28.75	21.6	5.8		6.5		7.2		•
	035			35	24.64	25.2	6.7		7.6		8.4		•
	040			40	21.56	28.8	7.7		8.6		9.6		•
	045			45	19.17	32.4	8.6		9.7		10.8		•
	050			50	17.25	36.0	9.6		10.8		12.0		•
	055			55	15.68	39.6	10.6		11.9		13.2		•
	060			60	14.38	43.2	11.5		13.0		14.4		•
	065			65	13.27	46.8	12.5		14.0		15.6		•
	070			70	12.32	50.4	13.4		15.1		16.8		•
075	75	11.50	54.0	14.4	16.2	18.0	•						
080	80	10.78	57.6	15.4	17.3	19.2	•						
TH	10-020	10	5	20	61.34	14.4	3.8	235	4.3	265	4.8	294	•
	025			25	49.07	18.0	4.8		5.4		6.0		•
	030			30	40.90	21.6	5.8		6.5		7.2		•
	035			35	35.05	25.2	6.7		7.6		8.4		•
	040			40	30.67	28.8	7.7		8.6		9.6		•
	045			45	27.26	32.4	8.6		9.7		10.8		•
	050			50	24.54	36.0	9.6		10.8		12.0		•
	055			55	22.31	39.6	10.6		11.9		13.2		•
	060			60	20.45	43.2	11.5		13.0		14.4		•
	065			65	18.87	46.8	12.5		14.0		15.6		•
	070			70	17.53	50.4	13.4		15.1		16.8		•
	075			75	16.36	54.0	14.4		16.2		18.0		•
	080			80	15.34	57.6	15.4		17.3		19.2		•
090	90	13.63	64.8	17.3	19.4	21.6	•						
TH	12-020	12	6	20	86.34	14.4	3.8	333	4.3	373	4.8	422	•
	025			25	69.07	18.0	4.8		5.4		6.0		•
	030			30	57.56	21.6	5.8		6.5		7.2		•
	035			35	49.34	25.2	6.7		7.6		8.4		•
	040			40	43.17	28.8	7.7		8.6		9.6		•
	045			45	38.37	32.4	8.6		9.7		10.8		•
	050			50	34.54	36.0	9.6		10.8		12.0		•
	055			55	31.40	39.6	10.6		11.9		13.2		•
	060			60	28.78	43.2	11.5		13.0		14.4		•
	065			65	26.57	46.8	12.5		14.0		15.6		•
	070			70	24.67	50.4	13.4		15.1		16.8		•
	075			75	23.02	54.0	14.4		16.2		18.0		•
	080			80	21.59	57.6	15.4		17.3		19.2		•
090	90	19.19	64.8	17.3	19.4	21.6	•						
使用回數							100萬回	50萬回	30萬回				

品號		D	d	L	定數	a	F=L×19.2%		F=L×21.6%		F=L×24%		單價
TYPE	D - L	外徑	內徑	自由長	N/mm	密著長	壓縮量	荷重	壓縮量	荷重	壓縮量	荷重	
		mm	mm	mm		mm	mm	N	mm	N	mm	N	
TH	14-025	14	7	25	96.30	18.0	4.8	461	5.4	520	6.0	579	•
	030			30	80.25	21.6	5.8		6.5		7.2		•
	035			35	68.78	25.2	6.7		7.6		8.4		•
	040			40	60.19	28.8	7.7		8.6		9.6		•
	045			45	53.50	32.4	8.6		9.7		10.8		•
	050			50	48.15	36.0	9.6		10.8		12.0		•
	055			55	43.77	39.6	10.6		11.9		13.2		•
	060			60	40.12	43.2	11.5		13.0		14.4		•
	065			65	37.04	46.8	12.5		14.0		15.6		•
	070			70	34.39	50.4	13.4		15.1		16.8		•
	075			75	32.10	54.0	14.4		16.2		18.0		•
	080			80	30.09	57.6	15.4		17.3		19.2		•
	090			90	26.75	64.8	17.3		19.4		21.6		•
	100			100	24.07	72.0	19.2		21.6		24.0		•
TH	16-025	16	8	25	125.37	18.0	4.8	608	5.4	677	6.0	755	•
	030			30	104.48	21.6	5.8		6.5		7.2		•
	035			35	89.55	25.2	6.7		7.6		8.4		•
	040			40	78.36	28.8	7.7		8.6		9.6		•
	045			45	69.65	32.4	8.6		9.7		10.8		•
	050			50	62.69	36.0	9.6		10.8		12.0		•
	055			55	56.99	39.6	10.6		11.9		13.2		•
	060			60	52.24	43.2	11.5		13.0		14.4		•
	065			65	48.22	46.8	12.5		14.0		15.6		•
	070			70	44.78	50.4	13.4		15.1		16.8		•
	075			75	41.79	54.0	14.4		16.2		18.0		•
	080			80	39.18	57.6	15.4		17.3		19.2		•
	090			90	34.83	64.8	17.3		19.4		21.6		•
	100			100	31.34	72.0	19.2		21.6		24.0		•
125	125	25.07	90.0	24.0	27.0	30.0	•						
TH	18-025	18	9	25	157.96	18.0	4.8	765	5.4	853	6.0	951	•
	030			30	131.64	21.6	5.8		6.5		7.2		•
	035			35	112.83	25.2	6.7		7.6		8.4		•
	040			40	98.73	28.8	7.7		8.6		9.6		•
	045			45	87.76	32.4	8.6		9.7		10.8		•
	050			50	78.98	36.0	9.6		10.8		12.0		•
	055			55	71.80	39.6	10.6		11.9		13.2		•
	060			60	65.82	43.2	11.5		13.0		14.4		•
	065			65	60.75	46.8	12.5		14.0		15.6		•
	070			70	56.42	50.4	13.4		15.1		16.8		•
	075			75	52.65	54.0	14.4		16.2		18.0		•
	080			80	49.36	57.6	15.4		17.3		19.2		•
	090			90	43.88	64.8	17.3		19.4		21.6		•
	100			100	39.49	72.0	19.2		21.6		24.0		•
125	125	31.59	90.0	24.0	27.0	30.0	•						
TH	20-025	20	10	25	196.11	18.0	4.8	941	5.4	1059	6.0	1177	•
	030			30	163.43	21.6	5.8		6.5		7.2		•
	035			35	140.08	25.2	6.7		7.6		8.4		•
	040			40	122.57	28.8	7.7		8.6		9.6		•
	045			45	108.95	32.4	8.6		9.7		10.8		•
	050			50	98.06	36.0	9.6		10.8		12.0		•
	055			55	89.14	39.6	10.6		11.9		13.2		•
	060			60	81.71	43.2	11.5		13.0		14.4		•
	065			65	75.43	46.8	12.5		14.0		15.6		•
	070			70	70.04	50.4	13.4		15.1		16.8		•
	075			75	65.37	54.0	14.4		16.2		18.0		•
	080			80	61.28	57.6	15.4		17.3		19.2		•
	090			90	54.48	64.8	17.3		19.4		21.6		•
	100			100	49.03	72.0	19.2		21.6		24.0		•
125	125	39.22	90.0	24.0	27.0	30.0	•						
150	150	32.69	108.0	28.8	32.4	36.0	•						
使用回數							100萬回	50萬回	30萬回				

PS. 備註

- 荷重(N)=定數(N/mm)×壓縮量(mm)
- 密著長是參考值,製作時會有少許差異
- 耐熱溫度150°C
- 1N=0.101972 kgf

訂貨: 交期:

TH14-025

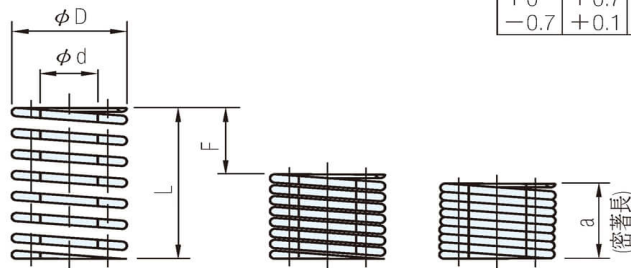

D	d	荷重	直角度	自由長	
+0	+0.7	±10%	±2°	≤50	≥55
-0.7	+0.1			±0.5	±1%

材質	顏色
SWOSC-V	茶

品號		D	d	L	定數	a	F=L×16%		F=L×18%		F=L×20%		單價
TYPE	D - L	外徑 mm	內徑 mm	自由長 mm	N/mm	密著長 mm	壓縮量 mm	荷重 N	壓縮量 mm	荷重 N	壓縮量 mm	荷重 N	
TB	08-010	8	4	10	166.11	7.6	1.6	255	1.8	299	2.0	343	•
	015			15	110.74	11.4	2.4		2.7		3.0		•
	020			20	83.06	15.2	3.2		3.6		4.0		•
	025			25	66.44	19.0	4.0		4.5		5.0		•
	030			30	55.37	22.8	4.8		5.4		6.0		•
	035			35	47.46	26.6	5.6		6.3		7.0		•
	040			40	41.53	30.4	6.4		7.2		8.0		•
	045			45	36.91	34.2	7.2		8.1		9.0		•
	050			50	33.22	38.0	8.0		9.0		10.0		•
	055			55	30.20	41.8	8.8		9.9		11.0		•
	060			60	27.69	45.6	9.6		10.8		12.0		•
	065			65	25.56	49.4	10.4		11.7		13.0		•
	070			70	23.73	53.2	11.2		12.6		14.0		•
	075			75	22.15	57.0	12.0		13.5		15.0		•
080	80	20.76	60.8	12.8	14.4	16.0	•						
TB	10-020	10	5	20	111.67	15.2	3.2	353	3.6	402	4.0	441	•
	025			25	89.33	19.0	4.0		4.5		5.0		•
	030			30	74.44	22.8	4.8		5.4		6.0		•
	035			35	63.81	26.6	5.6		6.3		7.0		•
	040			40	55.83	30.4	6.4		7.2		8.0		•
	045			45	49.63	34.2	7.2		8.1		9.0		•
	050			50	44.67	38.0	8.0		9.0		10.0		•
	055			55	40.61	41.8	8.8		9.9		11.0		•
	060			60	37.22	45.6	9.6		10.8		12.0		•
	065			65	34.36	49.4	10.4		11.7		13.0		•
	070			70	31.90	53.2	11.2		12.6		14.0		•
	075			75	29.78	57.0	12.0		13.5		15.0		•
	080			80	27.92	60.8	12.8		14.4		16.0		•
	090			90	24.81	68.4	14.4		16.2		18.0		•
TB	12-020	12	6	20	141.67	15.2	3.2	451	3.6	510	4.0	569	•
	025			25	113.33	19.0	4.0		4.5		5.0		•
	030			30	94.44	22.8	4.8		5.4		6.0		•
	035			35	80.95	26.6	5.6		6.3		7.0		•
	040			40	70.83	30.4	6.4		7.2		8.0		•
	045			45	62.96	34.2	7.2		8.1		9.0		•
	050			50	56.67	38.0	8.0		9.0		10.0		•
	055			55	51.52	41.8	8.8		9.9		11.0		•
	060			60	47.22	45.6	9.6		10.8		12.0		•
	065			65	43.59	49.4	10.4		11.7		13.0		•
	070			70	40.48	53.2	11.2		12.6		14.0		•
	075			75	37.78	57.0	12.0		13.5		15.0		•
	080			80	35.42	60.8	12.8		14.4		16.0		•
	090			90	31.48	68.4	14.4		16.2		18.0		•
TB	14-025	14	7	25	148.22	19.0	4.0	588	4.5	667	5.0	736	•
	030			30	123.52	22.8	4.8		5.4		6.0		•
	035			35	105.87	26.6	5.6		6.3		7.0		•
	040			40	92.64	30.4	6.4		7.2		8.0		•
	045			45	82.35	34.2	7.2		8.1		9.0		•
使用回數							100萬回	50萬回	30萬回				

品號		D	d	L	定數	a	F=L×16%		F=L×18%		F=L×20%		單價
TYPE	D - L	外徑 mm	內徑 mm	自由長 mm	N/mm	密著長 mm	壓縮量 mm	荷重 N	壓縮量 mm	荷重 N	壓縮量 mm	荷重 N	
TB	14-050	14	7	50	74.11	38.0	8.0	588	9.0	667	10.0	736	•
	055			55	67.37	41.8	8.8		9.9		11.0		•
	060			60	61.76	45.6	9.6		10.8		12.0		•
	065			65	57.01	49.4	10.4		11.7		13.0		•
	070			70	52.94	53.2	11.2		12.6		14.0		•
	075			75	49.41	57.0	12.0		13.5		15.0		•
	080			80	46.32	60.8	12.8		14.4		16.0		•
	090			90	41.17	68.4	14.4		16.2		18.0		•
	100			100	37.06	76.0	16.0		18.0		20.0		•
	TB			16-025	16	8	25		196.22		19.2		4.0
030		30	163.52	22.8			4.8	5.4	6.0	•			
035		35	140.16	26.6			5.6	6.3	7.0	•			
040		40	122.64	30.4			6.4	7.2	8.0	•			
045		45	109.01	34.2			7.2	8.1	9.0	•			
050		50	98.11	38.0			8.0	9.0	10.0	•			
055		55	89.19	41.8			8.8	9.9	11.0	•			
060		60	81.76	45.6			9.6	10.8	12.0	•			
065		65	75.47	49.4			10.4	11.7	13.0	•			
070		70	70.08	53.2			11.2	12.6	14.0	•			
075		75	65.41	57.0			12.0	13.5	15.0	•			
080		80	61.32	60.8			12.8	14.4	16.0	•			
090		90	54.51	68.4			14.4	16.2	18.0	•			
100		100	49.06	76.0			16.0	18.0	20.0	•			
125		125	39.24	95.0			20.0	22.5	25.0	•			
TB		18-025	18	9			25	246.22	19.0	4.0	981	4.5	1108
	030	30			205.19	22.8	4.8	5.4	6.0	•			
	035	35			175.87	26.6	5.6	6.3	7.0	•			
	040	40			153.89	30.4	6.4	7.2	8.0	•			
	045	45			136.79	34.2	7.2	8.1	9.0	•			
	050	50			123.11	38.0	8.0	9.0	10.0	•			
	055	55			111.92	41.8	8.8	9.9	11.0	•			
	060	60			102.59	45.6	9.6	10.8	12.0	•			
	065	65			94.70	49.4	10.4	11.7	13.0	•			
	070	70			87.94	53.2	11.2	12.6	14.0	•			
	075	75			82.07	57.0	12.0	13.5	15.0	•			
	080	80			76.94	60.8	12.8	14.4	16.0	•			
	090	90			68.40	68.4	14.4	16.2	18.0	•			
	100	100			61.56	76.0	16.0	18.0	20.0	•			
	125	125			49.24	95.0	20.0	22.5	25.0	•			
	TB	20-025			20	10	25	313.78	19.0	4.0		1255	
030		30	261.48	22.8			4.8	5.4	6.0	•			
035		35	224.13	26.6			5.6	6.3	7.0	•			
040		40	196.11	30.4			6.4	7.2	8.0	•			
045		45	174.32	34.2			7.2	8.1	9.0	•			
050		50	156.89	38.0			8.0	9.0	10.0	•			
055		55	142.63	41.8			8.8	9.9	11.0	•			
060		60	130.74	45.6			9.6	10.8	12.0	•			
065		65	120.68	49.4			10.4	11.7	13.0	•			
070		70	112.06	53.2			11.2	12.6	14.0	•			
075		75	104.59	57.0			12.0	13.5	15.0	•			
080		80	98.06	60.8			12.8	14.4	16.0	•			
090		90	87.16	68.4			14.4	16.2	18.0	•			
100		100	78.44	76.0			16.0	18.0	20.0	•			
125		125	62.76	95.0			20.0	22.5	25.0	•			
150		150	52.30	114.0			24.0	27.0	30.0	•			
使用回數							100萬回		50萬回		30萬回		

PS. 備註

- ・荷重(N)=定數(N/mm)×壓縮量(mm)
- ・密著長是參考值,製作時會有少許差異
- ・耐熱溫度150°C
- ・1N=0.101972 kgf

訂貨： 交期：

TB14-050

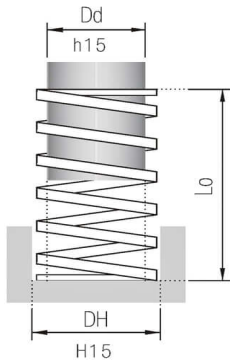

DH/Dd		H15		h15	
6 <	≦ 10	+0.58	-0	+0	-0.58
10 <	≦ 18	+0.70	-0	+0	-0.70
18 <	≦ 30	+0.84	-0	+0	-0.84
30 <	≦ 50	+1.00	-0	+0	-1.00
50 <	≦ 80	+1.20	-0	+0	-1.20

Lo ± %			N ± %	⌚
25~64	76~115	127~305		
±3%	±2.5%	±2%	±10%	

材質	顏色
SWOSC-V	綠

品號		DH	Dd	Lo	定數	最大	F=L0 × 25%	F=L0 × 30%	F=L0 × 35%	F=L0 × 40%	單價				
TYPE	DH-Lo	鑽孔徑	螺栓徑	自由長	N/mm	壓縮量	壓縮量	荷重	壓縮量	荷重		壓縮量	荷重	壓縮量	荷重
TJL	10-025	+0.58 -0	5	25	12.0	10.2	6.3	75	90	105	120	•			
	032			32	9.4	13.4	8.0					7.5	8.8	10.0	•
	038			38	7.9	16.1	9.5					9.6	11.2	12.8	•
	044			44	6.8	18.8	11.0					11.4	13.3	15.2	•
	051			51	5.9	22.0	12.8					13.2	15.4	17.6	•
	064			64	4.7	27.9	16.0					15.3	17.9	20.4	•
	076			76	3.9	33.4	19.0					19.2	22.4	25.6	•
	089			89	3.4	39.3	22.3					22.8	26.6	30.4	•
	102			102	2.9	45.2	25.5					26.7	31.2	35.6	•
	305			305	1.0	137.1	76.3					30.6	35.7	40.8	•
TJL	12.5-025	+0.7 -0	6.3	25	24.0	10.6	6.3	150	180	210	240	•			
	032			32	18.8	14.0	8.0					7.5	8.8	10.0	•
	038			38	15.8	17.0	9.5					9.6	11.2	12.8	•
	044			44	13.6	19.7	11.0					11.4	13.3	15.2	•
	051			51	11.8	23.2	12.8					13.2	15.4	17.6	•
	064			64	9.4	29.7	16.0					15.3	17.9	20.4	•
	076			76	7.9	35.2	19.0					19.2	22.4	25.6	•
	089			89	6.7	41.5	22.3					22.8	26.6	30.4	•
	102			102	5.9	47.2	25.5					26.7	31.2	35.6	•
	305			305	2.0	143.8	76.3					30.6	35.7	40.8	•
TJL	16-025	+0.7 -0	8	25	30.0	10.9	6.3	188	225	263	300	•			
	032			32	23.4	14.4	8.0					7.5	8.8	10.0	•
	038			38	19.7	17.4	9.5					9.6	11.2	12.8	•
	044			44	17.0	20.3	11.0					11.4	13.3	15.2	•
	051			51	14.7	23.9	12.8					13.2	15.4	17.6	•
	064			64	11.7	30.3	16.0					15.3	17.9	20.4	•
	076			76	9.9	36.3	19.0					19.2	22.4	25.6	•
	089			89	8.4	42.8	22.3					22.8	26.6	30.4	•
	102			102	7.4	49.3	25.5					26.7	31.2	35.6	•
	305			305	2.5	150.5	76.3					30.6	35.7	40.8	•
TJL	20-025	+0.84 -0	10	25	60.0	10.3	6.3	375	450	525	600	•			
	032			32	46.9	13.3	8.0					7.5	8.8	10.0	•
	038			38	39.5	16.2	9.5					9.6	11.2	12.8	•
	044			44	34.1	18.6	11.0					11.4	13.3	15.2	•
	051			51	29.4	21.5	12.8					13.2	15.4	17.6	•
	064			64	23.4	27.0	16.0					15.3	17.9	20.4	•
	076			76	19.7	32.6	19.0					19.2	22.4	25.6	•
	089			89	16.9	38.2	22.3					22.8	26.6	30.4	•
	102			102	14.7	45.0	25.5					26.7	31.2	35.6	•
	305			305	4.9	137.8	76.3					30.6	35.7	40.8	•
使用回數							300萬回	150萬回	50萬回	20萬回					

品 號		DH	Dd	Lo	定數	最大 壓縮量 ⚠	F=Lo × 25%		F=Lo × 30%		F=Lo × 35%		F=Lo × 40%		單價				
TYPE	DH-Lo	鑽孔徑 mm	螺栓徑 mm	自由長 mm	N/mm		壓縮量 mm	荷重 N	壓縮量 mm	荷重 N	壓縮量 mm	荷重 N	壓縮量 mm	荷重 N					
TJL	25-025	+0.84 -0	25	12.5	25	90.0	10.9	6.3	7.5	563	675	788	900	•					
	032				32	70.3	14.4	8.0	9.6	11.2	12.8	•							
	038				38	59.2	16.7	9.5	11.4	13.3	15.2	•							
	044				44	51.1	19.8	11.0	13.2	15.4	17.6	•							
	051				51	44.1	23.5	12.8	15.3	17.9	20.4	•							
	064				64	35.2	29.9	16.0	19.2	22.4	25.6	•							
	076				76	29.6	35.8	19.0	22.8	26.6	30.4	•							
	089				89	25.3	42.3	22.3	26.7	31.2	35.6	•							
	102				102	22.1	48.2	25.5	30.6	35.7	40.8	•							
	115				115	19.6	54.4	28.8	34.5	40.3	46.0	•							
	127				127	17.7	60.7	31.8	38.1	44.5	50.8	•							
	139				139	16.2	66.1	34.8	41.7	48.7	55.6	•							
	152				152	14.8	72.8	38.0	45.6	53.2	60.8	•							
	178				178	12.6	85.6	44.5	53.4	62.3	71.2	•							
	203				203	11.1	97.5	50.8	60.9	71.1	81.2	•							
	229				229	9.8	110.5	57.3	68.7	80.2	91.6	•							
305	305	7.4	147.3	76.3	91.5	106.8	122.0	•											
TJL	32-038	+1.0 -0	32	16	38	92.1	16.0	9.5	11.4	875	1050	1225	1400	•					
	044				44	79.5	18.5	11.0	13.2	15.4	17.6	•							
	051				51	68.6	22.1	12.8	15.3	17.9	20.4	•							
	064				64	54.7	28.5	16.0	19.2	22.4	25.6	•							
	076				76	46.1	34.4	19.0	22.8	26.6	30.4	•							
	089				89	39.3	40.8	22.3	26.7	31.2	35.6	•							
	102				102	34.3	45.8	25.5	30.6	35.7	40.8	•							
	115				115	30.4	51.5	28.8	34.5	40.3	46.0	•							
	127				127	27.6	57.6	31.8	38.1	44.5	50.8	•							
	139				139	25.2	63.5	34.8	41.7	48.7	55.6	•							
	152				152	23.0	69.2	38.0	45.6	53.2	60.8	•							
	178				178	19.7	82.4	44.5	53.4	62.3	71.2	•							
	203				203	17.2	94.0	50.8	60.9	71.1	81.2	•							
	229				229	15.3	106.3	57.3	68.7	80.2	91.6	•							
	254				254	13.8	118.2	63.5	76.2	88.9	101.6	•							
	305				305	11.5	142.7	76.3	91.5	106.8	122.0	•							
TJL	40-051	+1.0 -0	40	20	51	98.0	20.7	12.8	15.3	1250	1500	1750	2000	•					
	064				64	78.1	26.8	16.0	19.2	22.4	25.6	•							
	076				76	65.8	32.2	19.0	22.8	26.6	30.4	•							
	089				89	56.2	38.3	22.3	26.7	31.2	35.6	•							
	102				102	49.0	43.4	25.5	30.6	35.7	40.8	•							
	115				115	43.5	49.0	28.8	34.5	40.3	46.0	•							
	127				127	39.4	55.4	31.8	38.1	44.5	50.8	•							
	139				139	36.0	62.8	34.8	41.7	48.7	55.6	•							
	152				152	32.9	68.4	38.0	45.6	53.2	60.8	•							
	178				178	28.1	80.1	44.5	53.4	62.3	71.2	•							
	203				203	24.6	90.1	50.8	60.9	71.1	81.2	•							
	229				229	21.8	101.3	57.3	68.7	80.2	91.6	•							
	254				254	19.7	113.3	63.5	76.2	88.9	101.6	•							
	305				305	16.4	136.0	76.3	91.5	106.8	122.0	•							
	使用回數							300萬回	150萬回	50萬回	20萬回								

PS. 備註

- 1N=0.101972 kgf
- 耐熱溫度150°C
- 荷重(N)=定數(N/mm)×壓縮量(mm)

訂貨： 交期： 天 DH≤32
 TJL25-025 天 其它

Wa. 注意

- 彈簧的總壓縮量絕對不得大於最大壓縮量 ⚠
 否則將導致彈簧長度縮短,甚至斷裂

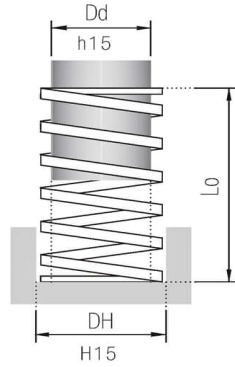

DH/Dd		H15		h15	
6 <	≦10	+0.58	-0	+0	-0.58
10 <	≦18	+0.70	-0	+0	-0.70
18 <	≦30	+0.84	-0	+0	-0.84
30 <	≦50	+1.00	-0	+0	-1.00
50 <	≦80	+1.20	-0	+0	-1.20

Lo ± %			N ± %	⌚
25~64	76~115	127~305		
±3%	±2.5%	±2%	±10%	

材質	顏色
SWOSC-V	藍

品號		DH	Dd	Lo	定數	最大	F=Lo×25%	F=Lo×30%	F=Lo×33.75%	F=Lo×37.5%			單價		
TYPE	DH-Lo	鑽孔徑	螺栓徑	自由長	N/mm	壓縮量	壓縮量	荷重	壓縮量	荷重	壓縮量	荷重		壓縮量	荷重
TJM	10-025	10	5	25	18.1	10.3	6.3	117	136	153	170	9.4	•		
	032			32	14.2	13.3	8.0					9.6	10.8	12.0	•
	038			38	11.9	15.9	9.5					11.4	12.8	14.3	•
	044			44	10.3	18.3	11.0					13.2	14.9	16.5	•
	051			51	8.9	21.6	12.8					15.3	17.2	19.1	•
	064			64	7.1	27.0	16.0					19.2	21.6	24.0	•
	076			76	6.0	32.3	19.0					22.8	25.7	28.5	•
	089			89	5.1	38.2	22.3					26.7	30.0	33.4	•
	102			102	4.4	43.6	25.5					30.6	34.4	38.3	•
	305			305	1.5	134.2	76.3					91.5	102.9	114.4	•
TJM	12.5-025	12.5	6.3	25	32.0	10.2	6.3	200	240	270	300	9.4	•		
	032			32	25.0	13.0	8.0					9.6	10.8	12.0	•
	038			38	21.1	15.6	9.5					11.4	12.8	14.3	•
	044			44	18.2	18.0	11.0					13.2	14.9	16.5	•
	051			51	15.7	21.1	12.8					15.3	17.2	19.1	•
	064			64	12.5	26.5	16.0					19.2	21.6	24.0	•
	076			76	10.5	31.8	19.0					22.8	25.7	28.5	•
	089			89	9.0	37.7	22.3					26.7	30.0	33.4	•
	102			102	7.8	43.1	25.5					30.6	34.4	38.3	•
	115			115	7.0	49.1	28.8					34.5	38.8	43.1	•
305	305	2.6	131.7	76.3	91.5	102.9	114.4	•							
TJM	16-025	16	8	25	53.3	9.8	6.3	333	400	450	500	9.4	•		
	032			32	41.7	12.7	8.0					9.6	10.8	12.0	•
	038			38	35.1	15.3	9.5					11.4	12.8	14.3	•
	044			44	30.3	17.9	11.0					13.2	14.9	16.5	•
	051			51	26.1	20.7	12.8					15.3	17.2	19.1	•
	064			64	20.8	26.2	16.0					19.2	21.6	24.0	•
	076			76	17.5	31.4	19.0					22.8	25.7	28.5	•
	089			89	15.0	37.7	22.3					26.7	30.0	33.4	•
	102			102	13.1	43.8	25.5					30.6	34.4	38.3	•
	115			115	11.6	49.3	28.8					34.5	38.8	43.1	•
127	127	10.5	54.3	31.8	38.1	42.9	47.6	•							
305	305	4.4	131.5	76.3	91.5	102.9	114.4	•							
TJM	20-025	20	10	25	85.3	9.8	6.3	533	640	720	800	9.4	•		
	032			32	66.7	12.7	8.0					9.6	10.8	12.0	•
	038			38	56.1	15.3	9.5					11.4	12.8	14.3	•
	044			44	48.5	18.0	11.0					13.2	14.9	16.5	•
	051			51	41.8	21.2	12.8					15.3	17.2	19.1	•
	064			64	33.3	27.3	16.0					19.2	21.6	24.0	•
	076			76	28.1	32.4	19.0					22.8	25.7	28.5	•
	089			89	24.0	38.4	22.3					26.7	30.0	33.4	•
	102			102	20.9	42.6	25.5					30.6	34.4	38.3	•
	115			115	18.6	48.6	28.8					34.5	38.8	43.1	•
127	127	16.8	54.0	31.8	38.1	42.9	47.6	•							
139	139	15.3	59.5	34.8	41.7	46.9	52.1	•							
152	152	14.0	65.9	38.0	45.6	51.3	57.0	•							
178	178	12.0	77.9	44.5	53.4	60.1	66.8	•							
203	203	10.5	89.3	50.8	60.9	68.5	76.1	•							
305	305	7.0	135.0	76.3	91.5	102.9	114.4	•							
使用回數							300萬回	150萬回	50萬回	20萬回					

品號		DH	Dd	Lo	定數	最大 壓縮量 ⚠	F=Lo×25%		F=Lo×30%		F=Lo×33.75%		F=Lo×37.5%		單價		
TYPE	DH-Lo	鑽孔徑 mm	螺栓徑 mm	自由長 mm	N/mm		壓縮量 mm	荷重 N	壓縮量 mm	荷重 N	壓縮量 mm	荷重 N	壓縮量 mm	荷重 N			
TJM	25-025	+0.84 -0	25	12.5	25	128.0	9.5	6.3	800	960	1080	1200	1200	•			
	032				32	100.0	12.3	8.0						7.5	8.4	9.4	•
	038				38	84.2	14.9	9.5						9.6	10.8	12.0	•
	044				44	72.7	17.2	11.0						11.4	12.8	14.3	•
	051				51	62.7	19.9	12.8						13.2	14.9	16.5	•
	064				64	50.0	25.4	16.0						15.3	17.2	19.1	•
	076				76	42.1	30.6	19.0						19.2	21.6	24.0	•
	089				89	36.0	36.2	22.3						22.8	25.7	28.5	•
	102				102	31.4	41.8	25.5						26.7	30.0	33.4	•
	115				115	27.8	47.6	28.8						30.6	34.4	38.3	•
	127				127	25.2	52.8	31.8						34.5	38.8	43.1	•
	139				139	23.0	57.6	34.8						38.1	42.9	47.6	•
	152				152	21.1	63.2	38.0						41.7	46.9	52.1	•
	178				178	18.0	73.5	44.5						45.6	51.3	57.0	•
	203				203	15.8	83.9	50.8						53.4	60.1	66.8	•
229	229	14.0	95.0	57.3	60.9	68.5	76.1	•									
305	305	10.5	126.8	76.3	68.7	77.3	85.9	•									
					91.5	102.9	114.4	•									
TJM	32-038	+1.0 -0	32	16	38	154.4	14.9	9.5	1467	1760	1980	2200	2200	•			
	044				44	133.3	17.5	11.0						11.4	12.8	14.3	•
	051				51	115.0	20.6	12.8						13.2	14.9	16.5	•
	064				64	91.7	25.5	16.0						15.3	17.2	19.1	•
	076				76	77.2	30.8	19.0						19.2	21.6	24.0	•
	089				89	65.9	36.7	22.3						22.8	25.7	28.5	•
	102				102	57.5	42.6	25.5						26.7	30.0	33.4	•
	115				115	51.0	48.6	28.8						30.6	34.4	38.3	•
	127				127	46.2	53.3	31.8						34.5	38.8	43.1	•
	139				139	42.2	55.6	34.8						38.1	42.9	47.6	•
	152				152	38.6	61.0	38.0						41.7	46.9	52.1	•
	178				178	33.0	71.4	44.5						45.6	51.3	57.0	•
	203				203	28.9	82.6	50.8						53.4	60.1	66.8	•
	229				229	25.6	92.9	57.3						60.9	68.5	76.1	•
	254				254	23.1	103.6	63.5						68.7	77.3	85.9	•
305	305	19.2	124.2	76.3	76.2	85.7	95.3	•									
					91.5	102.9	114.4	•									
TJM	40-051	+1.0 -0	40	20	51	156.9	19.6	12.8	2000	2400	2700	3000	3000	•			
	064				64	125.0	25.0	16.0						15.3	17.2	19.1	•
	076				76	105.3	30.3	19.0						19.2	21.6	24.0	•
	089				89	89.9	35.7	22.3						22.8	25.7	28.5	•
	102				102	78.4	41.1	25.5						26.7	30.0	33.4	•
	115				115	69.6	46.6	28.8						30.6	34.4	38.3	•
	127				127	63.0	52.3	31.8						34.5	38.8	43.1	•
	139				139	57.6	53.8	34.8						38.1	42.9	47.6	•
	152				152	52.6	59.0	38.0						41.7	46.9	52.1	•
	178				178	44.9	68.9	44.5						45.6	51.3	57.0	•
	203				203	39.4	78.1	50.8						53.4	60.1	66.8	•
	229				229	34.9	88.4	57.3						60.9	68.5	76.1	•
	254				254	31.5	98.6	63.5						68.7	77.3	85.9	•
	305				305	26.2	117.2	76.3						76.2	85.7	95.3	•
														91.5	102.9	114.4	•
使用回數							300萬回		150萬回		50萬回		20萬回				

PS. 備註

- 1N=0.101972 kgf
- 耐熱溫度150°C
- 荷重(N)=定數(N/mm)×壓縮量(mm)

訂貨： 交期： DH≤32
 TJM25-025 其它

Wa. 注意

- 彈簧的總壓縮量絕對不得大於最大壓縮量 ⚠
- 否則將導致彈簧長度縮短,甚至斷裂

品 號		DH	Dd	Lo	定數	最大	F=Lo×20%	F=Lo×25%	F=Lo×27.5%	F=Lo×30%	單 價				
TYPE	DH-Lo	鑽孔徑	螺栓徑	自由長	N/mm	壓縮量	壓縮量	荷重	壓縮量	荷重		壓縮量	荷重		
		mm	mm	mm		⚠	mm	N	mm	N	mm	N			
TJH	25-025	25	12.5	25	266.7	7.6	5.0	1333	6.3	1667	6.9	1833	7.5	2000	•
	032			32	208.3	10.1	6.4		8.0		8.8		9.6		•
	038			38	175.4	11.6	7.6		9.5		10.5		11.4		•
	044			44	151.5	13.4	8.8		11.0		12.1		13.2		•
	051			51	130.7	15.9	10.2		12.8		14.0		15.3		•
	064			64	104.2	20.5	12.8		16.0		17.6		19.2		•
	076			76	87.7	24.8	15.2		19.0		20.9		22.8		•
	089			89	74.9	29.4	17.8		22.3		24.5		26.7		•
	102			102	65.4	34.0	20.4		25.5		28.1		30.6		•
	115			115	58.0	38.6	23.0		28.8		31.6		34.5		•
	127			127	52.5	42.8	25.4		31.8		34.9		38.1		•
	139			139	48.0	47.1	27.8		34.8		38.2		41.7		•
	152			152	43.9	51.6	30.4		38.0		41.8		45.6		•
	178			178	37.5	60.9	35.6		44.5		49.0		53.4		•
	203			203	32.8	69.6	40.6		50.8		55.8		60.9		•
229	229	29.1	78.7	45.8	57.3	63.0	68.7	•							
305	305	21.9	105.5	61.0	76.3	83.9	91.5	•							
TJH	32-038	32	16	38	298.2	12.5	7.6	2267	9.5	2833	10.5	3117	11.4	3400	•
	044			44	257.6	14.1	8.8		11.0		12.1		13.2		•
	051			51	222.2	17.2	10.2		12.8		14.0		15.3		•
	064			64	177.1	21.6	12.8		16.0		17.6		19.2		•
	076			76	149.1	26.7	15.2		19.0		20.9		22.8		•
	089			89	127.3	30.9	17.8		22.3		24.5		26.7		•
	102			102	111.1	32.4	20.4		25.5		28.1		30.6		•
	115			115	98.6	36.8	23.0		28.8		31.6		34.5		•
	127			127	89.2	40.6	25.4		31.8		34.9		38.1		•
	139			139	81.5	44.9	27.8		34.8		38.2		41.7		•
	152			152	74.6	49.8	30.4		38.0		41.8		45.6		•
	178			178	63.7	56.7	35.6		44.5		49.0		53.4		•
	203			203	55.8	66.5	40.6		50.8		55.8		60.9		•
	229			229	49.5	75.9	45.8		57.3		63.0		68.7		•
	254			254	44.6	84.1	50.8		63.5		69.9		76.2		•
305	305	37.2	100.3	61.0	76.3	83.9	91.5	•							
TJH	40-051	40	20	51	326.8	15.8	10.2	3333	12.8	4167	14.0	4583	15.3	5000	•
	064			64	260.4	19.7	12.8		16.0		17.6		19.2		•
	076			76	219.3	24.1	15.2		19.0		20.9		22.8		•
	089			89	187.3	29.2	17.8		22.3		24.5		26.7		•
	102			102	163.4	34.3	20.4		25.5		28.1		30.6		•
	115			115	144.9	39.3	23.0		28.8		31.6		34.5		•
	127			127	131.2	44.0	25.4		31.8		34.9		38.1		•
	139			139	119.9	48.7	27.8		34.8		38.2		41.7		•
	152			152	109.6	54.1	30.4		38.0		41.8		45.6		•
	178			178	93.6	63.7	35.6		44.5		49.0		53.4		•
	203			203	82.1	73.1	40.6		50.8		55.8		60.9		•
	229			229	72.8	83.6	45.8		57.3		63.0		68.7		•
	254			254	65.6	92.9	50.8		63.5		69.9		76.2		•
	305			305	54.6	113.0	61.0		76.3		83.9		91.5		•
	使用回數								300萬回		150萬回		50萬回		20萬回

PS. 備註

- 1N=0.101972 kgf
- 耐熱溫度150°C
- 荷重(N)=定數(N/mm)×壓縮量(mm)

訂貨： 交期： 天 DH≤32
 TJH25-025 天 其它

Wa. 注意

- 彈簧的總壓縮量絕對不得大於最大壓縮量 ⚠
- 否則將導致彈簧長度縮短,甚至斷裂

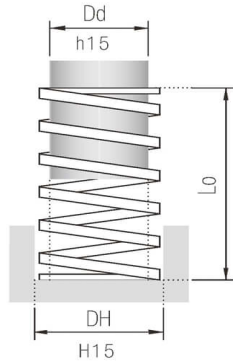

DH/Dd		H15		h15	
6 <	≦ 10	+0.58	-0	+0	-0.58
10 <	≦ 18	+0.70	-0	+0	-0.70
18 <	≦ 30	+0.84	-0	+0	-0.84
30 <	≦ 50	+1.00	-0	+0	-1.00
50 <	≦ 80	+1.20	-0	+0	-1.20

Lo ± %		N ± %	⌚
25~64	76~115		
±3%	±2.5%	±2%	±10%

材質	顏色
SWOSC-V	紅

品 號		DH	Dd	Lo	定數	最大	F=Lo×20%		F=Lo×25%		F=Lo×27.5%		F=Lo×30%		單 價			
TYPE	DH-Lo	鑽孔徑	螺栓徑	自由長	N/mm	壓縮量	壓縮量	荷重	壓縮量	荷重	壓縮量	荷重	壓縮量	荷重				
TJH	50-064	50 +1.0 -0	25 +0 -0.84	64	390.6	19.5	12.8	5000	16.0	6250	17.6	6875	19.2	7500	•			
	076			76	328.9	23.9	15.2		19.0		20.9		22.8		•			
	089			89	280.9	29.0	17.8		22.3		24.5		26.7		•			
	102			102	245.1	32.0	20.4		25.5		28.1		30.6		•			
	115			115	217.4	36.9	23.0		28.8		31.6		34.5		•			
	127			127	196.9	41.6	25.4		31.8		34.9		38.1		•			
	139			139	179.9	46.2	27.8		34.8		38.2		41.7		•			
	152			152	164.5	51.1	30.4		38.0		41.8		45.6		•			
	178			178	140.4	60.9	35.6		44.5		49.0		53.4		•			
	203			203	123.2	70.4	40.6		50.8		55.8		60.9		•			
	229			229	109.2	80.3	45.8		57.3		63.0		68.7		•			
	254			254	98.4	89.6	50.8		63.5		69.9		76.2		•			
	305			305	82.0	109.4	61.0		76.3		83.9		91.5		•			
TJH	63-076	63 +1.2 -0	38 +0 -1.0	76	526.3	23.0	15.2	8000	19.0	10000	20.9	11000	22.8	12000	•			
	089			89	449.4	27.3	17.8		22.3		24.5		26.7		•			
	102			102	392.2	31.4	20.4		25.5		28.1		30.6		•			
	115			115	347.8	36.7	23.0		28.8		31.6		34.5		•			
	127			127	315.0	39.8	25.4		31.8		34.9		38.1		•			
	152			152	263.2	49.4	30.4		38.0		41.8		45.6		•			
	178			178	224.7	57.5	35.6		44.5		49.0		53.4		•			
	203			203	197.0	68.0	40.6		50.8		55.8		60.9		•			
	229			229	174.7	74.7	45.8		57.3		63.0		68.7		•			
	254			254	157.5	83.6	50.8		63.5		69.9		76.2		•			
	305			305	131.1	102.2	61.0		76.3		83.9		91.5		•			
	使用回數								300萬回		150萬回		50萬回		20萬回			

PS. 備註

- 1N=0.101972 kgf
- 耐熱溫度150°C
- 荷重(N)=定數(N/mm)×壓縮量(mm)

訂貨： 交期： DH≤32
 TJH50-064 其它

Wa. 注意

- 彈簧的總壓縮量絕對不得大於最大壓縮量 ⚠
- 否則將導致彈簧長度縮短,甚至斷裂

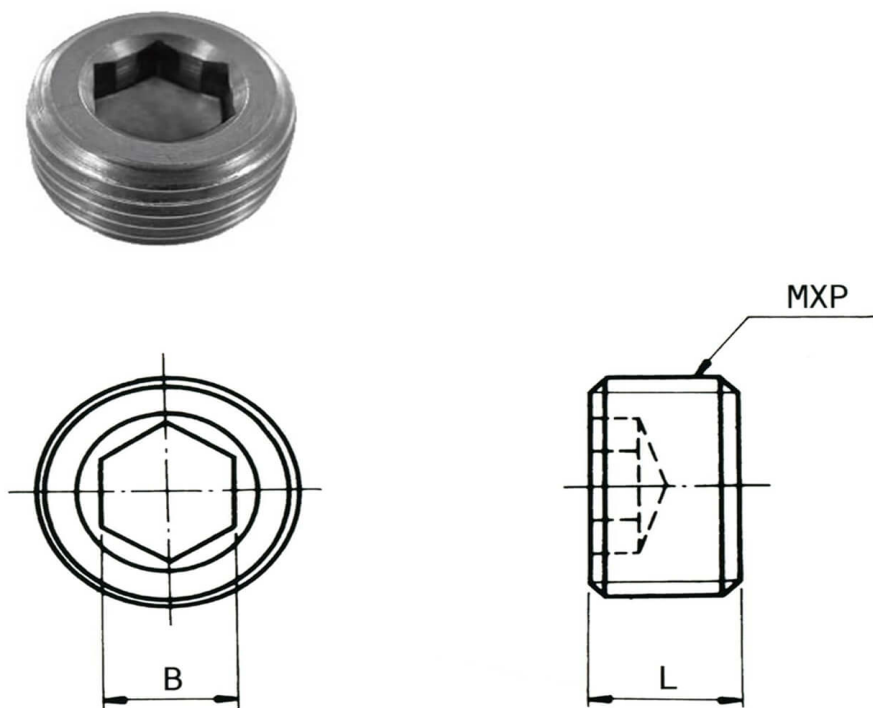

材質：S45C
 HRC：34~40°
 染黑處理

型號	D	B	L	P	適用彈簧外徑
GS	12	6	10	1.5	8
	14				10
	16				12
	18	14			14
	20				16
	22	12	12		18
	24	14			20
	26				22
	30	17			25.27
	33.34.35				30

訂購方法：型號-D × 數量
 例：GS-18 × 50PCS

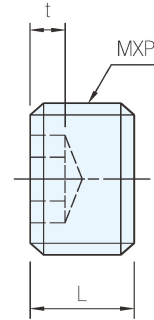
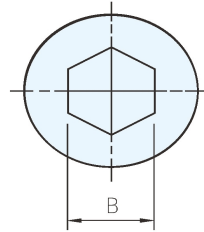

材質	硬度	處理
S45C	HRC34~43	染黑

品號		M × P	L	B	t	單價
TYPE	M					
NSW (標準型)	03	3×0.5	3	1.5	1.2	•
	04	4×0.7	4	2.0	1.5	•
	05	5×0.8	5	2.5	2.0	•
	06	6×1.0	6	3.0	3.5	•
	08	8×1.25	8	4.0	5.0	•
	10	10×1.5	10	5.0	6.0	•
	12	12×1.5		6.0	5.0	•
	14	14×1.5		8.0	•	
	16	16×1.5		10.0	•	
	18	18×1.5		12.0	•	
	20	20×1.5	12	14.0	6.0	•
	22	22×1.5				•
	24	24×1.5				•
	25	25×1.5				•
	26	26×1.5				•
	27	27×1.5				•
	28	28×1.5	18	17.0	10.0	•
	30	30×1.5				•
	33	33×1.5				•
	36	36×1.5				•
38	38×1.5	•				
40	40×1.5	•				
42	42×1.5	•				
45	45×1.5	•				

品號		M × P	L	B	t	單價
TYPE	M-L					
NSWS (短型)	8-6	8×1.25	6	4	3	•
	10-6	10×1.5		5		•
	12-6	12×1.5		6		•
	14-6	14×1.5				•
	16-6	16×1.5		8		•
	18-6	18×1.5		10		•
	20-8	20×1.5	•			
	22-8	22×1.5	•			
	24-8	24×1.5	8	14	4	•
	25-8	25×1.5				•
	26-8	26×1.5				•
	27-8	27×1.5				•
	28-8	28×1.5				•
	30-8	30×1.5				17
	33-8	33×1.5	•			

訂貨： 交期：
NSW03

Ex. 使用例

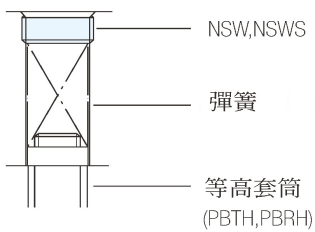

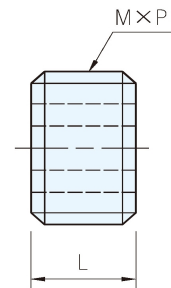
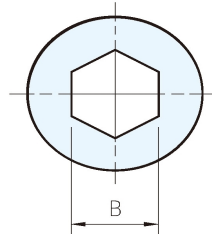

材質	硬度	處理
S45C	HRC34~43	染黑

品號		M × P	L	B	單價	
TYPE	M					
NSWA (標準型)	08	8×1.25	8	4	•	
	10	10×1.5		5	•	
	12	12×1.5		6	•	
	14	14×1.5			•	
	16	16×1.5		8	•	
	18	18×1.5		10	10	•
	20	20×1.5	•			
	22	22×1.5	12		•	
	24	24×1.5	12		•	
	25	25×1.5			•	
	26	26×1.5			14	•
	27	27×1.5				•
	28	28×1.5			•	
	30	30×1.5		17	•	
33	33×1.5	•				

品號		M × P	L	B	單價
TYPE	M-L				
NSWAS (短型)	8-6	8×1.25	6	4	•
	10-6	10×1.5		5	•
	12-6	12×1.5		6	•
	14-6	14×1.5			•
	16-6	16×1.5		8	•
	18-6	18×1.5		10	10
	20-8	20×1.5	•		
	22-8	22×1.5	12		•
	24-8	24×1.5	14		•
	25-8	25×1.5			•
	26-8	26×1.5			•
	27-8	27×1.5			•
	28-8	28×1.5			•
	30-8	30×1.5		17	•
	33-8	33×1.5	•		

Ex. 使用例

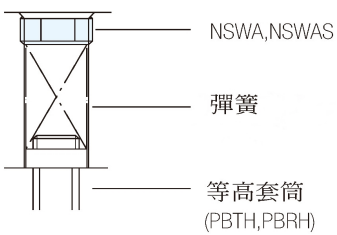

訂貨： 交期： 天
NSWA08

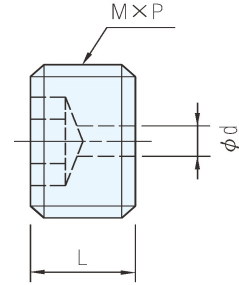
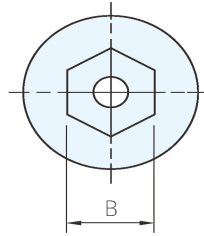

材質	硬度	處理
S45C	HRC34~43	染黑

品號		M x P	L	B	d	單價
TYPE	M					
NSWH (標準型)	12	12 x 1.5	10	6	3	•
	14	14 x 1.5				•
	16	16 x 1.5		8		•
	18	18 x 1.5				•
	20	20 x 1.5		10		•
	22	22 x 1.5				•
	24	24 x 1.5	12	10	5	•
	25	25 x 1.5				•
	26	26 x 1.5		14		•
	27	27 x 1.5				•
	28	28 x 1.5		17		•
	30	30 x 1.5				•
33	33 x 1.5	•				

品號		M x P	L	B	d	單價
TYPE	M-L					
NSWSH (短型)	12-6	12 x 1.5	6	6	3	•
	14-6	14 x 1.5				•
	16-6	16 x 1.5		8		•
	18-6	18 x 1.5				•
	20-8	20 x 1.5		10		•
	22-8	22 x 1.5				•
	24-8	24 x 1.5	8	10	5	•
	25-8	25 x 1.5				•
	26-8	26 x 1.5		14		•
	27-8	27 x 1.5				•
	28-8	28 x 1.5		17		•
	30-8	30 x 1.5				•
	33-8	33 x 1.5	•			

Ex. 使用例

訂貨： 交期：

NSWH12

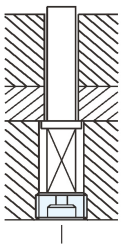

NSWH
NSWSH

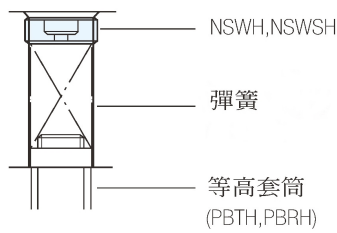



材質	硬度	處理
S45C	HRC34~43	染黑

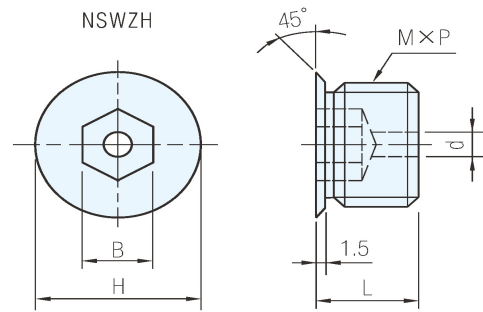
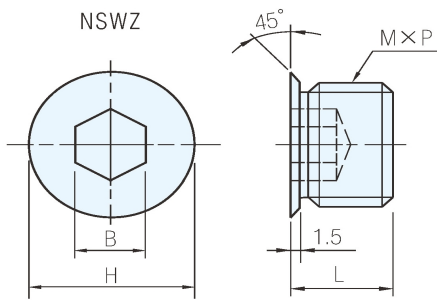

品號		M × P	L	B	H	單價
TYPE	M					
NSWZ	06	6 × 1.0	8	3	9	•
	08	8 × 1.25	10	4	11	•
	10	10 × 1.5	12	5	13	•
	12	12 × 1.5		6	15	•
	14	14 × 1.5		7	17	•
	16	16 × 1.5		8	19	•
	18	18 × 1.5	15	10	21	•
	20	20 × 1.5		11	23	•
	22	22 × 1.5		12	25	•
	24	24 × 1.5		14	13	27
	25	25 × 1.5	14		28	•
	26	26 × 1.5	15		29	•
	27	27 × 1.5	16		30	•
	28	28 × 1.5	17	17	31	•
30	30 × 1.5	18		33	•	
33	33 × 1.5	19		36	•	

品號		M × P	L	B	H	d	單價
TYPE	M						
NSWZH	10	10 × 1.5	12	5	13	3	•
	12	12 × 1.5		6	15		•
	14	14 × 1.5		7	17		•
	16	16 × 1.5		8	19		•
	18	18 × 1.5	15	10	21	5	•
	20	20 × 1.5		11	23		•
	22	22 × 1.5		12	25		•
	24	24 × 1.5		14	13		27
	25	25 × 1.5	14		28	•	
	26	26 × 1.5	15		29	•	
	27	27 × 1.5	16		30	•	
	28	28 × 1.5	17	17	31	5	•
	30	30 × 1.5		18	33		•
	33	33 × 1.5		19	36		•

訂貨： 交期：

NSWZ06

SP 特長

- 座的部份可防止止付螺絲鬆脫
- W倒角可控制止付螺絲下鎖深度

Ex. 使用例

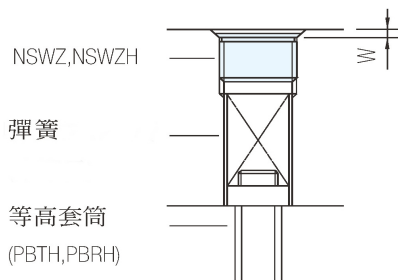



PSW



PSSW



PSWP



SCFPK

PSW
PSSW
PSWP

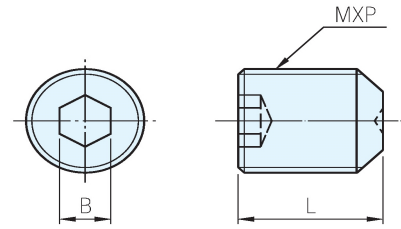

SCFPK

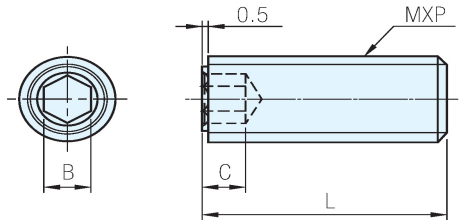

Type	材質	硬度	處理
PSW	SCM435	HRC45~53	染黑
PSSW	SUS304	-	-
PSWP	尼龍	-	-
SCFPK	PEEK	-	-

品號 TYPE	MXP	B	L													
			04	05	06	08	10	12	16	20	25	30	35	40		
PSW 鋼	03	3X0.5	1.5	•	•	•	•	•	•	•	•	•				
	04	4X0.7	2.0	•	•	•	•	•	•	•	•	•				
	05	5X0.8	2.5		•	•	•	•	•	•	•	•	•			
	06	6X1.0	3.0			•	•	•	•	•	•	•	•	•	•	•
	08	8X1.25	4.0				•	•	•	•	•	•	•	•	•	•
	10	10X1.5	5.0					•	•	•	•	•	•	•	•	•
	12	12X1.75	6.0						•	•	•	•	•	•	•	•
16	16X2.0	8.0							•	•	•	•	•	•	•	

品號 TYPE	MXP	B	L													
			04	05	06	08	10	12	16	20	25	30	35	40		
PSSW 不銹鋼	03	3X0.5	1.5	•	•	•	•	•	•	•	•	•				
	04	4X0.7	2.0	•	•	•	•	•	•	•	•	•				
	05	5X0.8	2.5		•	•	•	•	•	•	•	•	•			
	06	6X1.0	3.0			•	•	•	•	•	•	•	•	•	•	•
	08	8X1.25	4.0				•	•	•	•	•	•	•	•	•	•
	10	10X1.5	5.0					•	•	•	•	•	•	•	•	•
	12	12X1.75	6.0						•	•	•	•	•	•	•	•
16	16X2.0	8.0							•	•	•	•	•	•	•	

品號 TYPE	MXP	B	L													
			04	05	06	08	10	12	16	20	25	30	35	40		
PSWP 尼龍	03	3X0.5	1.5				•	•	•	•	•	•				
	04	4X0.7	2.0		•	•	•	•	•	•	•	•				
	05	5X0.8	2.5			•	•	•	•	•	•	•	•			
	06	6X1.0	3.0			•	•	•	•	•	•	•	•	•		
	08	8X1.25	4.0				•	•	•	•	•	•	•	•	•	•
	10	10X1.5	5.0					•	•	•	•	•	•	•	•	•
12	12X1.75	6.0						•	•	•	•	•	•	•	•	

品號 TYPE	MXP	B	C	L												
				04	05	06	08	10	12	15	20	25	30	35	40	
SCFPK	03	3X0.5	1.5	2.0	•	•	•	•	•	•	•	•				
	04	4X0.7	2.0	2.5		•	•	•	•	•	•	•	•			
	05	5X0.8	2.5	3.0		•	•	•	•	•	•	•	•	•		
	06	6X1.0	3.0	3.5			•	•	•	•	•	•	•	•	•	•
	08	8X1.25	4.0	5.0				•	•	•	•	•	•	•	•	•

Wa. 注意

- PSWP之M3和M4尼龍螺絲是一字型溝，不是內六角
- 其他型式無頭內六角螺絲(止付螺絲)請參考彈簧單元(NSW，NSWA，NSWH)
- PEEK是性能優異的工程塑膠，耐化學藥品性佳(一般藥品中，只能溶解於濃硫酸)其耐磨性、耐熱性、耐燃性、耐加水分解性也非常好，連續使用溫度180°C

訂貨： - 交期： 天
PSW03 - 04

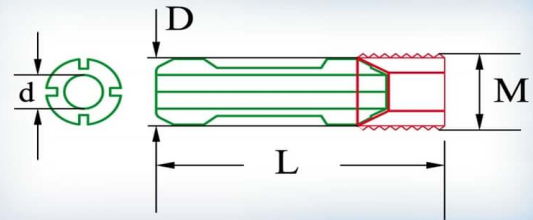

D	d	M	L
7	3.2	m8-P1.25	27, 37, 47
10.5	5.2	m12-P1.5	27, 37, 47, 57
14.5	8.2	m16-P1.5	37, 47, 57

註. D為鑽孔尺寸 d為下料孔尺寸

27L	建議使用28~35下座板厚
37L	建議使用38~45下座板厚
47L	建議使用48~55下座板厚
57L	建議使用58~65下座板厚

訂購: AIRB—M—L—數量
 範例: AIRB—M12—37L—10
 交期: 訂購次日出貨

數量	1~9個	10~29個	30~49個	
單價	M16	380元	345元	320元
	M12	340元	310元	290元
	M8	300元	270元	255元

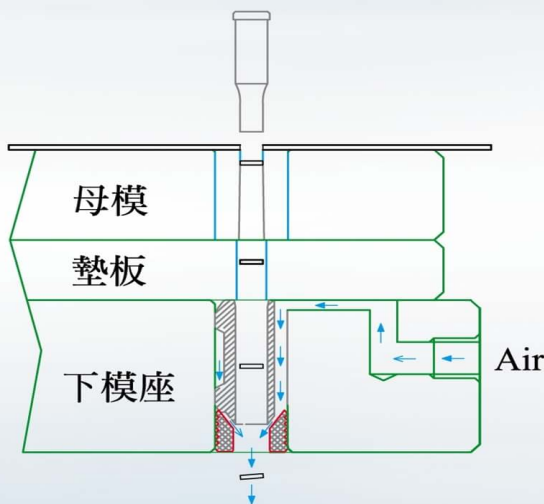

吸料銷運作示意圖 (多孔時, 使用)

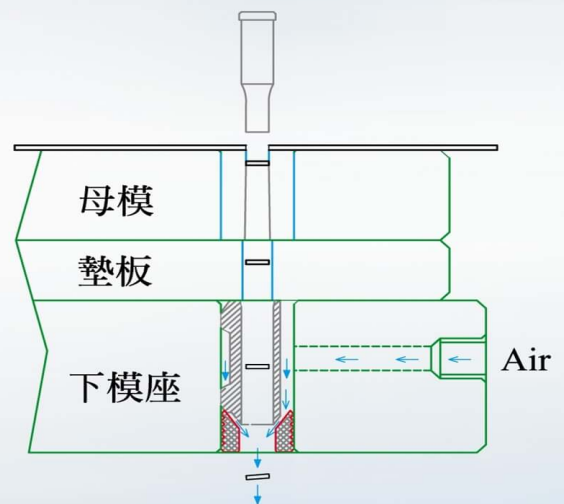

吸料銷運作示意圖 (單孔時, 使用)



不銹鋼 (Ma) 材質: SUS301 (t=0.005~0.50) (Ha) 硬度: HRC47~54

碳鋼 (Ma) 材質: AISI1095 (Ha) 硬度: HRC47~58

不銹鋼 (Ma) 材質: SUS301 (t=0.60~2.00) (Ha) 硬度: HRC42~49

銅 (Ma) 材質: C27400 (Ha) 硬度: HV173

單位: mm

品號	種類		捲形									
	寬度		6		12.7		12.7		12.7		25	
	長度		5M	5M	1M	1M	2M	2M	5M	5M	5M	5M
	厚度	公差	不銹鋼	碳鋼	不銹鋼	碳鋼	不銹鋼	碳鋼	不銹鋼	碳鋼	不銹鋼	碳鋼
SSS 不銹鋼	0.005	±0.001	-	-	•	-	•	-	•	-	-	-
	0.01	±0.002	-	-	•	•	•	•	•	•	•	-
	0.02		-	-	•	•	•	•	•	•	•	-
	0.025		-	-	•	-	•	-	•	-	-	-
	0.03	±0.003	-	-	•	•	•	•	•	•	•	•
	0.04		-	-	•	•	•	•	•	•	•	•
	0.05		•	•	•	•	•	•	•	•	•	•
	0.06		•	-	•	•	•	•	•	•	•	•
	0.07	±0.004	•	-	•	•	•	•	•	•	•	•
	0.075		-	-	•	-	•	-	•	-	-	-
0.08	•		-	•	•	•	•	•	•	•	•	
0.09	•		-	•	•	•	•	•	•	•	•	
0.10	±0.005	•	•	•	•	•	•	•	•	•	•	
0.12		-	-	•	•	•	•	•	•	-	-	
0.15		•	•	•	•	•	•	•	•	•	•	
0.18		-	-	•	•	•	•	•	•	-	-	
CCC 碳鋼	0.20	±0.006	•	•	•	•	•	•	•	•	•	•
	0.25	±0.007	•	•	•	•	•	•	•	•	•	-
	0.30	±0.008	•	•	•	•	•	•	•	•	•	•
	0.35		-	-	•	•	•	•	•	•	-	-
	0.40	±0.009	•	•	•	•	•	•	•	•	•	•
	0.45		-	-	•	•	•	•	•	•	-	-
	0.50	±0.010	•	•	•	•	•	•	•	•	•	•
	0.60		-	-	•	•	•	•	•	•	•	•
0.70	±0.012	-	-	•	•	•	•	•	•	•	•	
BBB 銅	0.80	±0.013	-	-	•	•	•	•	•	•	•	•
	0.90		-	-	•	•	•	•	•	•	•	•
	1.00	-	-	•	•	•	•	•	•	•	•	
	SSH 不銹鋼	1.50	±0.020	-	-	-	-	-	-	-	-	-
2.00		±0.050	-	-	-	-	-	-	-	-	-	



MSSA/MSSB * 記號
 NP
 WPW/NPV (D=02~06)

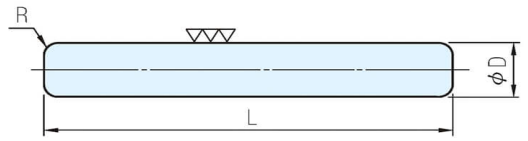

MSSA/MSSB
 WPW/NPV (D=08, 10)

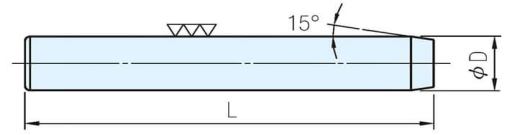

材質	硬度
SUJ2	HRC58

D	R	品 號		L																
		TYPE	D	6	8	10	15	20	25	30	35	40	45	50	55	60	65	70	80	
+0.003 0	0.4	MSSA	1.5	*	*	*														
			02	*	*	*	*	*												
			2.5	*	*	*	*	*	*	*										
			03	*	*	*	*	*	*	*	.	.								
	+0.005 0		0.6	04		*	*	*	*	*	*					
			0.8	05		*	*	*	*	*	*					
			0.9	06		*	*	*	*	*	*			
			-	08				
		10						
		12								

D	R	品 號		L																
		TYPE	D	6	8	10	15	20	25	30	35	40	45	50	55	60	65	70	80	
0 -0.003	0.4	MSSB	1.5	*	*	*														
			02	*	*	*	*	*												
			2.5	*	*	*	*	*	*	*	.	.								
			03	*	*	*	*	*	*	*	.	.								
	0 -0.005		0.6	04		*	*	*	*	*	*					
			0.8	05		*	*	*	*	*	*					
			0.9	06		*	*	*	*	*	*			
			-	08				
		10						
		12								

D	R	品 號		L							
		TYPE	D	6	8	10	15	20	25	30	
+0.010 +0.005	0.4	NP	1.5	*	*	*					
			02	*	*	*	*	*			
			2.5	*	*	*	*	*	*	*	
			03	*	*	*	*	*	*	*	
			04		*	*	*	*	*	*	
			05		*	*	*	*	*	*	
	0.6	06		*	*	*	*	*	*		
	0.8			*	*	*	*	*	*		
	0.9			*	*	*	*	*	*		

訂貨： - 交期： 天

- MSSA1.5 - 6
- MSSB1.5 - 6
- NP1.5 - 6
- NPV02 - 6

D	R	品 號		L										備註		
		WPW	NPV	TYPE	D	6	8	10	15	20	25	30	40		50	60
+0.002 0	0 -0.002	WPW NPV		02	*	*	*									
				03		*	*	*	*	*	*					
				04			*	*	*	*	*	*				
				05			*	*	*	*	*	*				
				06			*	*	*	*	*	*				
				08				
										
											

高精
 精密型

Wa. 注意

- *表示兩端是R角
- 特殊公差和尺寸歡迎洽詢

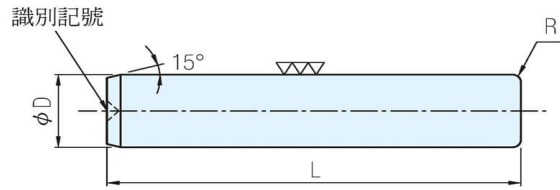

材質	硬度
SUS420	HRC45-50

D	品 號		L					
	TYPE	D	4	6	8	10	15	20
+0.003 0	MSSE	01		
		1.5		.	.	.		
02			
03			
+0.005 0		04	

D	品 號		L					
	TYPE	D	4	6	8	10	15	20
0 -0.003	MSSF	01		
		1.5		.	.	.		
02			
03			
0 -0.005		04	

Ps. 備註
 · 非規格品歡迎洽詢

訂貨： - 交期：

MSSE01 - 4
 MSSF01 - 4

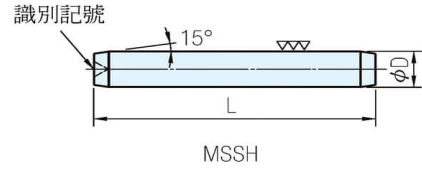
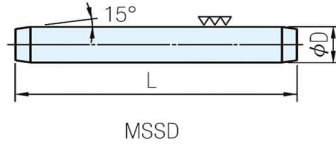
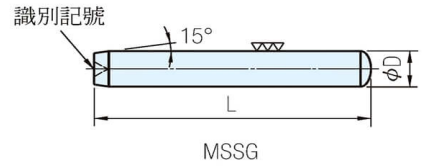
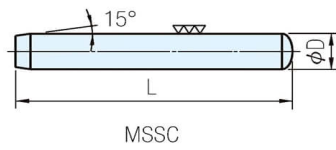

品號	材質	處理	硬度
MSSC·MSSD	SUS303	固溶化	-
MSSG·MSSH	SUS420	熱處理	HRC45~HRC50

D	品號		L									
	TYPE	D	4	6	8	10	15	20	25	30	40	50
+0.008 +0.002	MSSC	01	•	•	•	•						
		1.5	•	•	•	•						
		02	•	•	•	•	•	•				
		2.5		•	•	•	•	•	•			
+0.012 +0.004		03		•	•	•	•	•	•	•		
		04		•	•	•	•	•	•	•	•	
		05			•	•	•	•	•	•	•	•
+0.015 +0.006		06				•	•	•	•	•	•	•
		08					•	•	•	•	•	•
		10						•	•	•	•	•

D	品號		L									
	TYPE	D	4	6	8	10	15	20	25	30	40	50
+0 -0.010	MSSD	01	•	•	•	•						
		1.5	•	•	•	•						
		02	•	•	•	•	•					
		2.5		•	•	•	•	•	•			
+0 -0.012		03		•	•	•	•	•	•	•		
		04		•	•	•	•	•	•	•	•	
		05			•	•	•	•	•	•	•	•
+0 -0.015		06				•	•	•	•	•	•	•
		08					•	•	•	•	•	•
		10						•	•	•	•	•

D	品號		L					
	TYPE	D	4	6	8	10	15	20
+0.008 +0.002	MSSG	01	•	•	•	•		
		1.5	•	•	•	•		
		02	•	•	•	•	•	•
		03		•	•	•	•	•
+0.012 +0.004		04		•	•	•	•	

D	品號		L					
	TYPE	D	4	6	8	10	15	20
+0 -0.010	MSSH	01	•	•	•	•		
		1.5	•	•	•	•		
		02	•	•	•	•	•	•
		03		•	•	•	•	•
+0 -0.012		04		•	•	•	•	

Ps. 備註
· 非規格品歡迎洽詢

訂貨： - 交期：

MSSC01 - 4

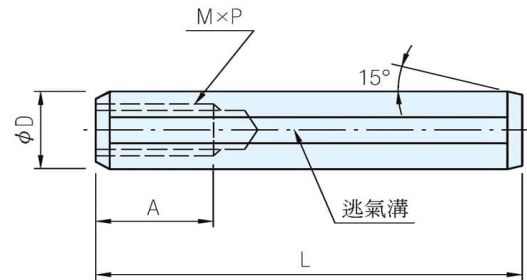

TYPE	材質	硬度
NPBG	S45C	45~50HRC
NPBGP	SUS416	45~50HRC

M × P	A	D h7	品 號		L													
			TYPE	D	10	15	20	25	30	35	40	45	50	60	70	80		
4 × 0.7	8	0 -0.012	NPBG 鋼	6	
				8	
6 × 1.0	10	0 -0.015		10
				12	
8 × 1.25	15	0 -0.018		13
				16	

MXP	A	D h7	品 號		L												
			TYPE	D	10	15	20	25	30	35	40	45	50	60	70	80	
4 × 0.7	8	0 -0.012	NPBGP 不銹鋼	6
5 × 0.8				8
6 × 1.0	10	0 -0.015		10

Ps. 備註

- 僅D6~10時，A=6
- 拔銷器請參考FMGM(本單元)

訂貨： - 交期： 天

NPBG 6 - 20
NPBGP 6 - 10

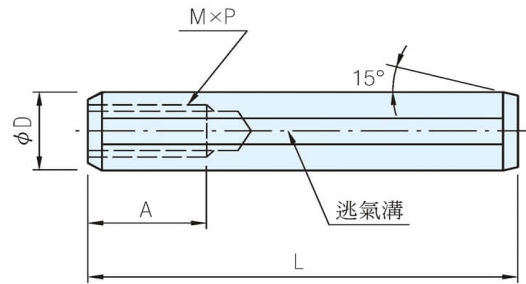

TYPE	材質	硬度
NPB	S45C	45~50HRC
NPBN		
NPBNP	SUS416	45~50HRC

M × P	A	D m6	品 號		L												
			TYPE	D	10	15	20	25	30	35	40	45	50	60	70	80	
4 × 0.7	8	+0.012 +0.004	NPBN 鋼	6	
				8	
6 × 1.0	10	+0.015 +0.006		10	
				12		
8 × 1.25	15	+0.018 +0.007		13	
				16		
10 × 1.5	18	+0.021 +0.008		20	

M × P	A	D m6	品 號		L												
			TYPE	D	10	15	20	25	30	35	40	45	50	60	70	80	
4 × 0.7	8	+0.012 +0.004	NPBNP 不銹鋼	6		
5 × 0.8				8		
6 × 1.0				10		

M × P	A	D p6	品 號		L												
			TYPE	D	10	15	20	25	30	35	40	45	50	60	70	80	
4 × 0.7	8	+0.020 +0.012	NPB 鋼	6		
				8		
6 × 1.0	10	+0.024 +0.015		10			
				12			
8 × 1.25	15	+0.029 +0.018		13			
				16			
10 × 1.5	18	+0.035 +0.022		20			

Ps. 備註

- 僅D6~10時, A=6
- 拔銷器請參考FMGM(本單元)

訂貨： 品 號 - L 交期： 1 天

NPBN 6 - 10

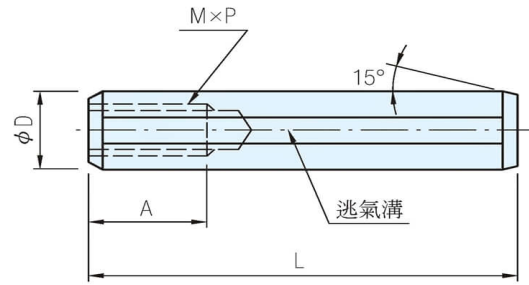

TYPE	材質	硬度
NPBS	SUJ2	HRC58
NPBSE	SUS416	45~50HRC

M × P	A	D	品 號		L														
			TYPE	D	10	15	20	25	30	35	40	45	50	60	70	80			
4X0.7	8	+0.010 +0.005	NPBS 鋼	6			•			•									
5X0.8				8						•									
6X1.0	10			10															
				12															
8X1.25	15			13															
				16															

M × P	A	D	品 號		L														
			TYPE	D	10	15	20	25	30	35	40	45	50	60	70	80			
4×0.7	8	+0.010 +0.005	NPBSE 不銹鋼	6															
5×0.8				8															
6×1.0	10																		
8×1.25	15			12															
				13															

Ps. 備註

- 僅D6~10時, A=6
- 拔銷器請參考FMGM(本單元)

訂貨： - 交期： 天

NPBS 6 - 10
NPBSE 6 - 10

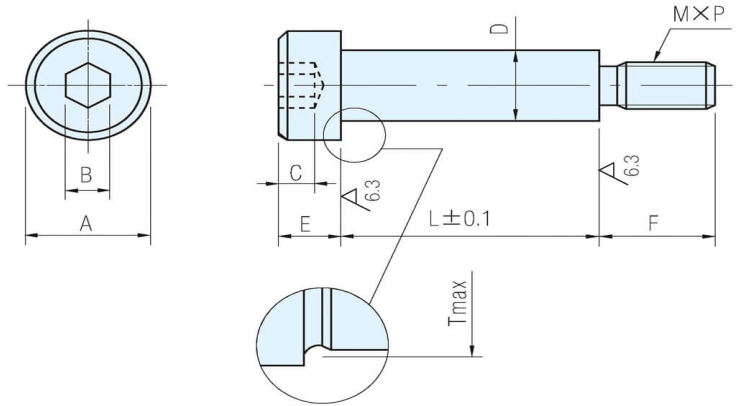

材質	硬度	處理
SCM435	HRC33~38	四三酸化鐵

Df9		A	B	C	E	F	T	M x P
6	-0.010 -0.040	10	3	2.4	4.5	10	6.5	5 x 0.8
6.5	-0.013 -0.049	13	4	3.3	5.5	11	7.0	6 x 1.0
8							8.7	
10	-0.016 -0.059	16	5	4.2	7.0	13	10.8	8 x 1.25
12							12.8	
13							14.0	
16	-0.020 -0.072	24	8	6.6	11.0	18	17.0	12 x 1.75
20							21.0	
20		30	10	8.8	14.0	22	21.0	16 x 2.0

品號		L																					
Type	D	10	12	16	20	25	30	35	40	45	50	55	60	65	70	75	80	85	90	95	100	110	120
MSB	06
	06.5
	08
	10
	12

品號		L																							
Type	D	15	16	20	25	30	35	40	45	50	55	60	65	70	75	80	85	90	95	100	110	120	130	140	150
MSB	13
	16
	20

PS. 備註

訂貨： 交期： 天

· 特殊長度和JIS規格,歡迎洽詢

MSB06-12



材質	處理
S45C	染黑, Fe ₃ O ₄

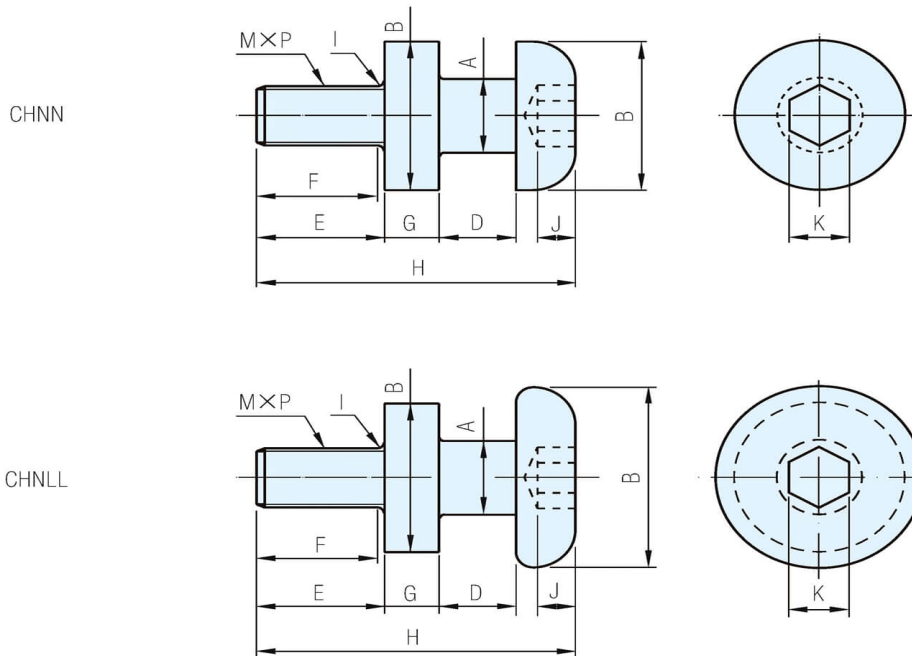

品號		N 鋼の場合 安全係數10	M×P	A	B		D		E	F	G	H		I	J	K	單價	
Type	M				CHNN	CHNLL	CHNN	CHNLL				CHNN	CHNLL				CHNN	CHNLL
CHNN CHNLL (大頭)	10	2452	10×1.5	13	32	42	10	18	20	16	8	46	54	1.5	5	8	•	•
	12	3530	12×1.75	16	36	48	13	20	24	20	10	57	64	1.5	6	10	•	•
	16	6669	16×2.0	20	40	52	18	25	30	25	13	75	82	2.0	9	14	•	•
	20	10395	20×2.5	25	48	62	20	28	37	32	16	90	98	2.0	12	17	•	•
	24	15004	24×3.0	32	58	76	25	33	47	40	20	111	119	2.5	13	19	•	•
	30	23830	30×3.5	36	68	88	30	40	56	48	22	131	141	3.0	16	22	•	•
	36	34814	36×4.0	40	78	100	30	40	68	58	25	148	158	3.0	18	27	•	•

■ 安裝方法 螺絲孔如下圖加工,CHNN/CHNLL的凸緣面和工作物面鎖到密著狀態下使用

訂貨： 交期： 天

CHNN10

M	d ₁	P
10	15	22
12	18	26
16	23	32
20	27	40
24	35	50
30	42	60
36	50	72

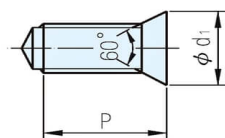

M	d ₂	P ₁	P ₂
10	12	22	5
12	14	26	6
16	18	32	6
20	22	40	6
24	28	50	8
30	34	60	9
36	40	72	11

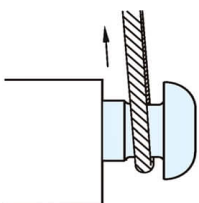
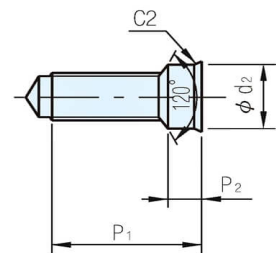



材質
SS41

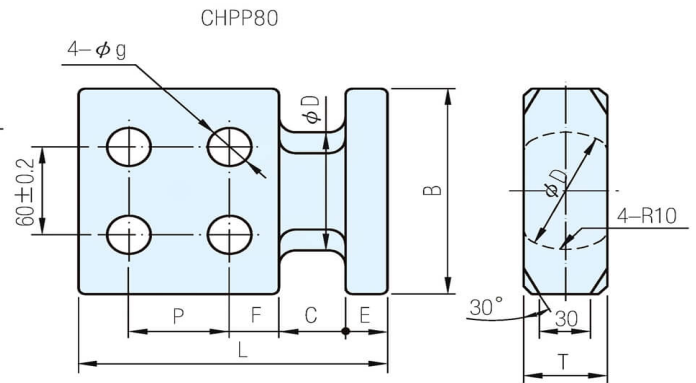
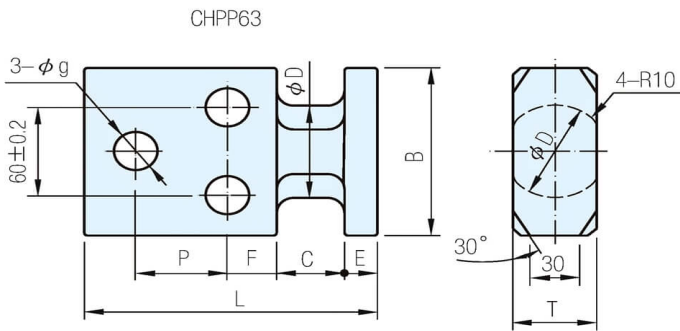
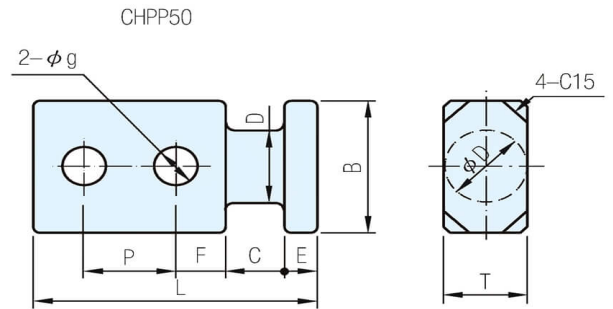
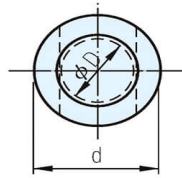
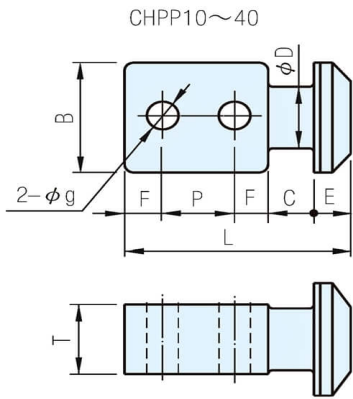

品號		D	d	B	T -0.5 -1.0	L	C	E	F	P ±0.2	g	N/1支 鋼の場合 安全係數10	單價
Type	φ D												
CHPP	10	10	28	28	18	50	10	8	8	16	7	1569	•
	12	12	32	32	20	56			10	18	9	3530	•
	16	16	36	36	24	67			13	22	11	4511	•
	20	20	40	40	26	88	18	10	15	30	14	5492	•
	25	25	48	48	35	92	20	12	15	30	14	6570	•
	32	32	55	55	40	118	25	13	20	40	18	12160	•
	40	40	70	70	50	138	30	15	24	45	22	19123	•
	50	49	-	90		170	35	20	30	55	26	27459	•
	63	63	-	115		175	40					39227	•
80	80	-	140	185		40	25	60	60	50995	•		

螺牙部長度	品號	單價
	Type M - L	(M24×P3.0)
全牙	CBB 24- 80	•
	CBB 24- 90	•
60	CBB 24-100	•
	CBB 24-110	•
	CBB 24-120	•

Wa. 注意

- CHPP50、60、80裝配螺絲(強度10.9)
- 吊索方向請與鎖緊螺絲同一方向
- 1N=0.101972kgf

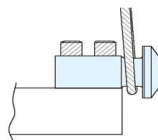

訂貨： 交期： 天
CHPP10



材質
SS41

CHPLL10~40

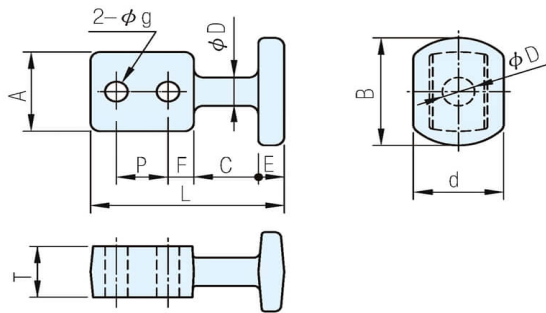

CHPLL50

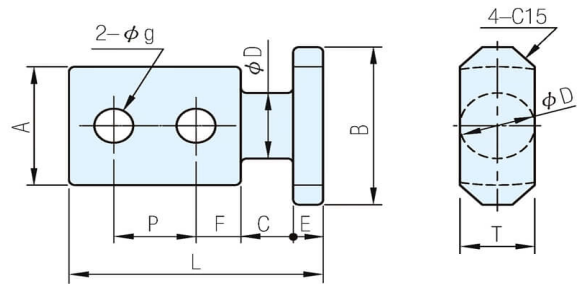

CHPLL63

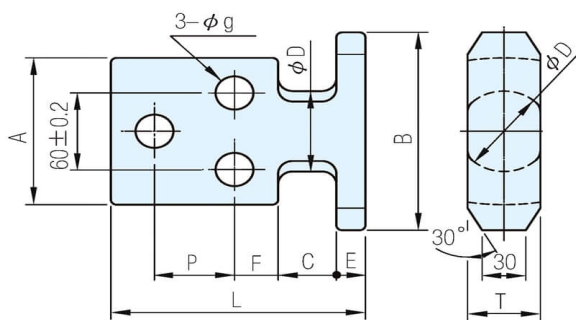

CHPLL80

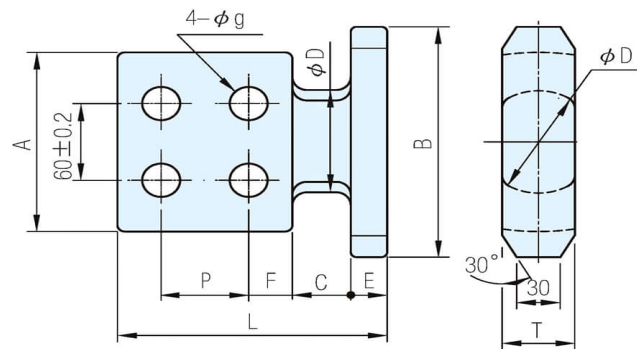

品號		A	B	C	d	T	L	E	F	P	g	N/1支 鋼の場合 安全係數10	單價
Type	D					^{-0.5}				^{±0.2}			
CHPLL	10	28	38	20	28	18	60	8	8	16	7	1569	•
	12	32	44		32	20	66		10	18	9	3530	•
	16	36	50		36	24	78	12	12	22	11	4511	•
	20	40	56	25	40	26	97	15	15	30	14	5492	•
	25	48	68		48	35	98		20	40	18	12160	•
	32	55	77	30	55	40	125	20	24	45	22	19123	•
	40	70	100	35	70	50	143		30	55	26	27459	•
	50	90	120		-		175	20	30	55	26	39227	•
	63	115	155	40	-		50	175	20	30	55	26	39227
	80	140	180		-	185		25	30	60	26	50995	•

螺牙部長度	品號	單價
	Type M - L	(M24 × P3.0)
全牙	CBB 24- 80	•
	CBB 24- 90	•
60	CBB 24-100	•
	CBB 24-110	•
	CBB 24-120	•
	CBB 24-120	•

Wa. 注意

- CHPLL50、60、80裝配螺絲(強度10.9)
- 吊索方向請與鎖緊螺絲同一方向
- 1N=0.101972kgf
- CHPLL80目前無法供應

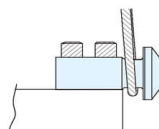

訂貨： 交期： 天 D≤63
CHPLL 10

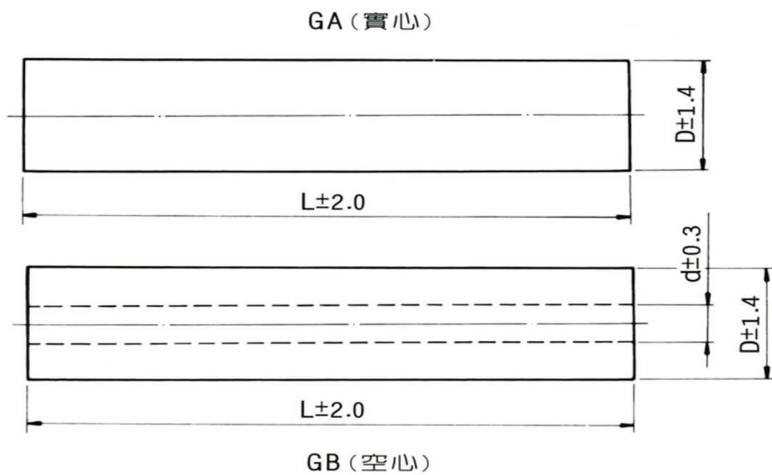

型號	實心優力膠規格			
	D	長度	D	長度
GA	10 φ	300	30 φ	500
	12 φ	300	32 φ	500
	14 φ	300	37 φ	500
	16 φ	300	40 φ	500
	18 φ	500	43 φ	500
	20 φ	500	45 φ	500
	22 φ	500	48 φ	500
	25 φ	500	50 φ	500
	28 φ	500	54 φ	500

型號	空心優力膠規格		
	D	d	L
GB	14 φ	6 φ	300
	16 φ	8 φ	300
	18 φ	8 φ	300
	18 φ	1 φ	300
	20 φ	8 φ	300
	20 φ	1 φ	300
	22 φ	8 φ	300
	25 φ	8 φ 12 φ	300
	30 φ	8M12 φ	300

訂購方法：型號-D×L×數量
 例：GA-18×500×10條
 註：優力膠可分、特級與A級



Type	材質	顏色
LOC680	嫌氣性樹脂	綠

品 號	容量 (ml)	單 價	黏度 (mPa.s)	使用溫度 範圍 (°C)	抗剪強度 kg/cm ²	最大黏著間隙		硬化時間 (hr)		硬化方法
						推薦間隙	單邊	活性面	不活性面	
LOC680	50	•	1250	-55~150	280	單邊 0.15	1~4	3~8	室溫	
	250					單邊 0.02~0.03				

Sp. 特長

- 適用於導套 LBBB、SGBLL、SGBHH、SGHZZ、SGBZZ、LRB、LRA、BGA、BGB、LBB、LBA……等或螺絲的接著

訂貨：

品 號	-	容量
-----	---	----

 交期：

1	天
---	---

LOC680 - 50
LOC680 - 250

Wa. 注意

- 活性面包括鋼、銅合金、鋁合金……等
- 不活性面包括不銹鋼、鋅、熱硬化塑膠、電鍍面……等
- 接著前接著面必須脫脂清洗處理

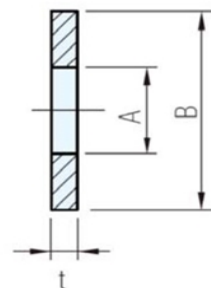
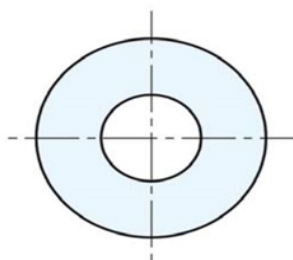

材質	硬度	處理
S45C	HRC48~52	染黑

D	d	t	品號
10	4.5	5	10
13	5.5	5	13
15	6.5	5	15
16	4.2	4	16
18	5.5	5	18-5.5
	6.5	5	18-6.5
	8.5	5	18-8.5
20	6.5	5	20-6.5
	8.5	5	20-8.5
21	10.5	5	21
22	6.5	5	22
25	6.5	5	25-6.5
	8.5	5	25-8.5
30	8.5	5	30-8.5
	10.5	5	30-10.5
35	10.5	5	35

訂購方式：品號KW-D * d * t
 例如：KW18 *5.5*5-50PCS

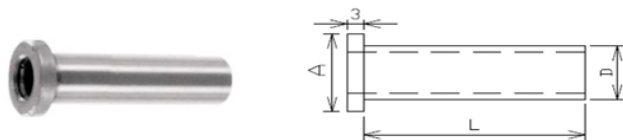

材質	硬度
S45C	HRC33~38

D	A +0 -0.2	d	品號		L																
			TYPE	D	20	25	30	35	40	45	50	55	60	65	70	75	80	85	90	95	100
-0.1 -0.3	13	6	CSR	9
	16	8		11
	18	10		13

訂購方式：品號CSR-D*L*數量
 例如：CSR-11*55L-100PCS

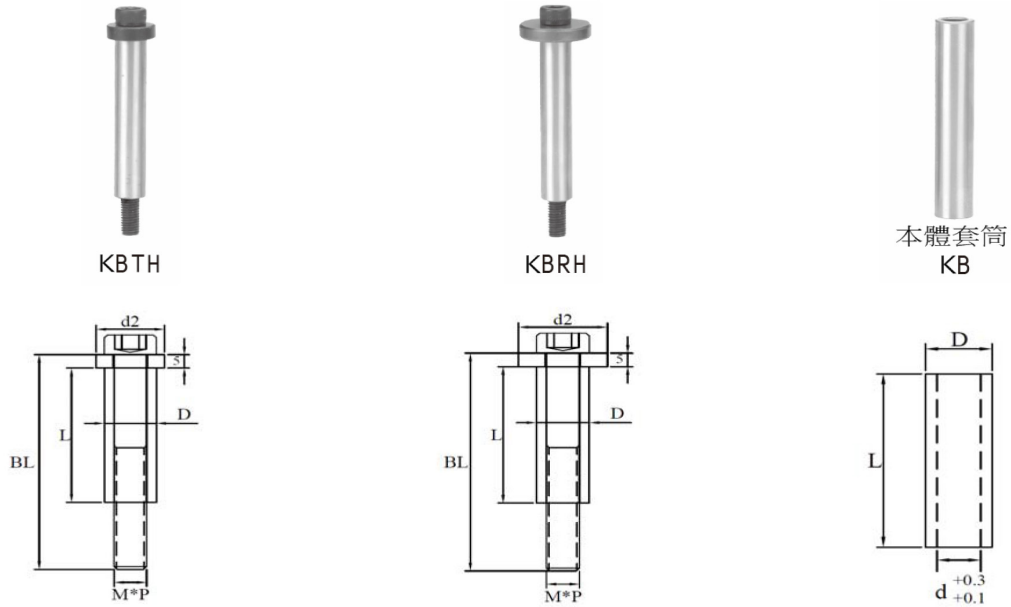

材質	硬度
S45C	HRC33~38

De9	公差	D	KBTH	KBRH	PB	M × P	品號		L	BL	KBRH (d2)
			d2	d2	d		TYPE	D	0.1mm單位	0.1mm單位	
10	-0.025 -0.061	10	15	20.22.25	6.5	M6*1.0	KBTH KBRH KB	10	10~100	30~130	15.18.20.22.25
13	-0.032 -0.075	13	18	25.27.30	8.5	M8*1.25		13	10~100	30~130	18.20.22.25
16		16	21	30.35	10.5	M10*1.5		16	10~100	30~130	21.30.35

訂購方式：品號-L-BL-d2
 例如：KBRH 13 -55-70-25

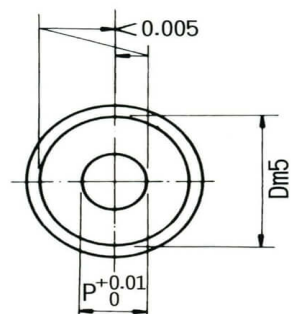
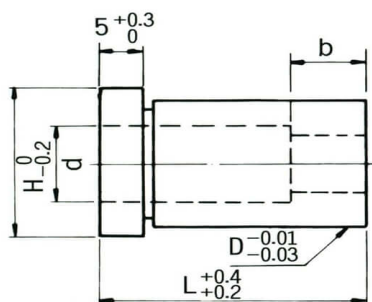

材質	傳統鋼材		粉末高速鋼					超硬碳化鎢		
	SKD-11	SKH-51	ASP-23	M4	ASP-60	T15	10V	G3	G4	G5
硬度	60~62	62~64	64~66	64~66	65~67	64~66	60~62	HRA87	HRA85	HRA84

型號	D	切口P	b	T	H	d	L
MA	6	1.0~2.5	3	4	8	3	15、18、20、22、25、30、32
	8	1.5~3.5	4	5	10	4	15、18、20、22、25、30、32
	10	2.0~4.5	5	5	13	5	15、18、20、22、25、30、32
	13	3.0~6.5	5	5	16	7	18、20、22、25、30、32、38
	16	5.2~8.5	5	5	19	9	18、20、22、25、30、32、38
	20	7.0~10.5	5	5	23	11	18、20、22、25、30、32、38
	25	9.0~14.0	6	5	28	15	18、20、22、25、30、32、38
	32	14.0~18.0	6	5	35	19	18、20、22、25、30、32、38
38	18.0~25.0	8	5	41	26	18、20、22、25、30、32、38	

訂購方法：型號-材質-D×P×L×數量
 例：MA-T15-8×5.2×25×20PCS

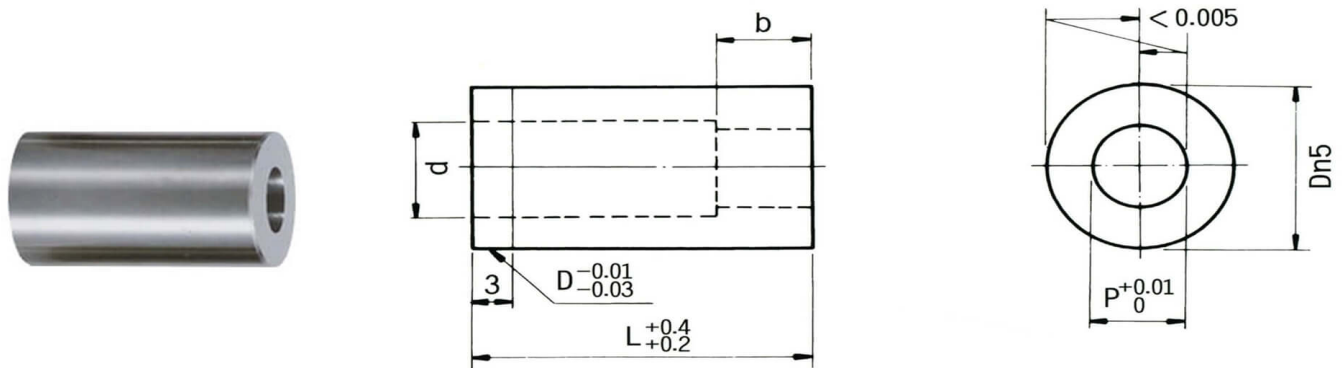

材質	傳統鋼材		粉末高速鋼					超硬碳化鎢		
	SKD-11	SKH-51	ASP-23	M4	ASP-60	T15	10V	G3	G4	G5
硬度	60~62	62~64	64~66	64~66	65~67	64~66	60~62	HRA87	HRA85	HRA84

型號	D	切口P	b	d	L
MB	6	1.0~2.5	3	3	15、18、20、22、25、30、32
	8	1.5~3.5	4	4	15、18、20、22、25、30、32
	10	2.0~4.5	5	5	15、18、20、22、25、30、32
	13	3.0~6.5	5	7	18、20、22、25、30、32、38
	16	5.0~8.5	5	9	18、20、22、25、30、32、38
	20	7.0~10.5	5	11	18、20、22、25、30、32、38
	25	9.0~14.0	6	15	18、20、22、25、30、32、38
	32	14.0~18.0	6	19	18、20、22、25、30、32、38
38	18.0~25.0	8	26	18、20、22、25、30、32、38	

訂購方法：型號-材質-D×P×L×數量
 例：MB-M4-6×1.5×25×20PCS

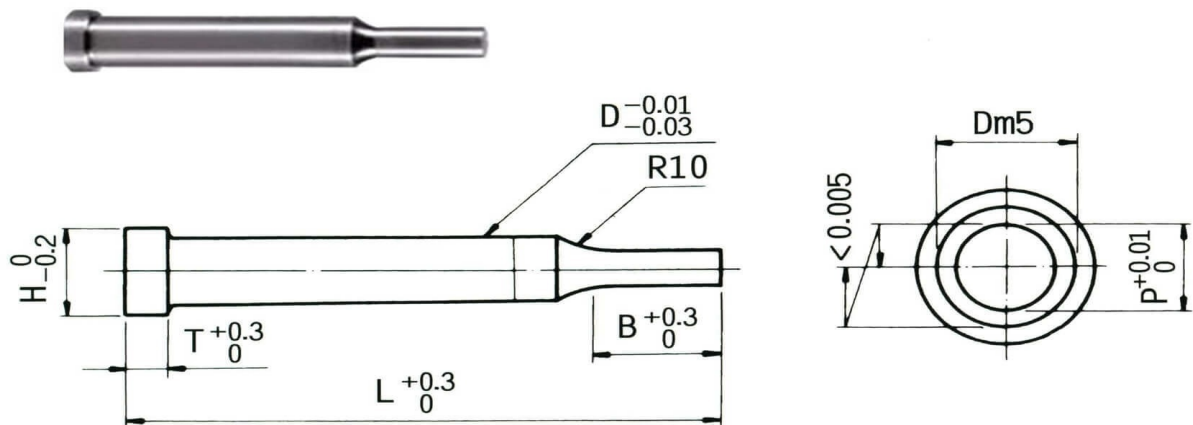

材質	傳統鋼材		粉末高速鋼					超硬碳化鎢		
	SKD-11	SKH-51	ASP-23	M4	ASP-60	T15	10V	G3	G4	G5
硬度	60~62	62~64	64~66	64~66	65~67	64~66	60~62	HRA87	HRA85	HRA84

型號	Dm5	P	B	H	T	L
A	4	1.0~3.9	6	6	4	40、50、60
	5	1.5~4.9	8	7	4	40、50、60
	6	2.0~5.9	10	8	4	40、50、60
	8	4.0~7.9	12	10	5	40、50、60、70、80
	10	5.0~9.9	15	13	5	40、50、60、70、80
	13	8.0~12.9	18	16	5	50、60、70、80
	16	10.0~15.9	18	19	5	50、60、70、80

訂購方法：材質-型號-D X P X L X 數量

例：M4-A-6X2.8X50X20PCS

註：任何材質均可按需求實施表面鍍鈦處理

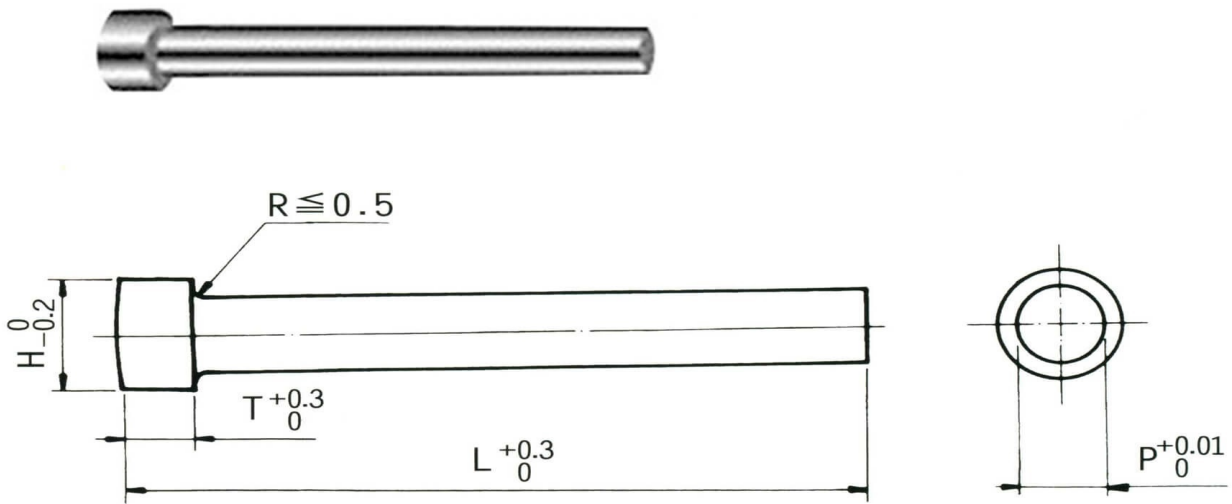

材質	傳統鋼材		粉末高速鋼					超硬碳化鎢		
	SKD-11	SKH-51	ASP-23	M4	ASP-60	T15	10V	G3	G4	G5
硬度	60~62	62~64	64~66	64~66	65~67	64~66	60~62	HRA87	HRA85	HRA84

型號	P0.1單位	H	T	L
B	1.0~2.5		4	40、50、60
	2.6~7.9	P+2	4	40、50、60、70、80
	8.0~9.9		5	40、50、60、70、80
	10.0~16.0	P+3	5	40、50、60、70、80

訂購方法：材質-型號-P X L X 數量

例：M4-B-3.0X60X20PCS

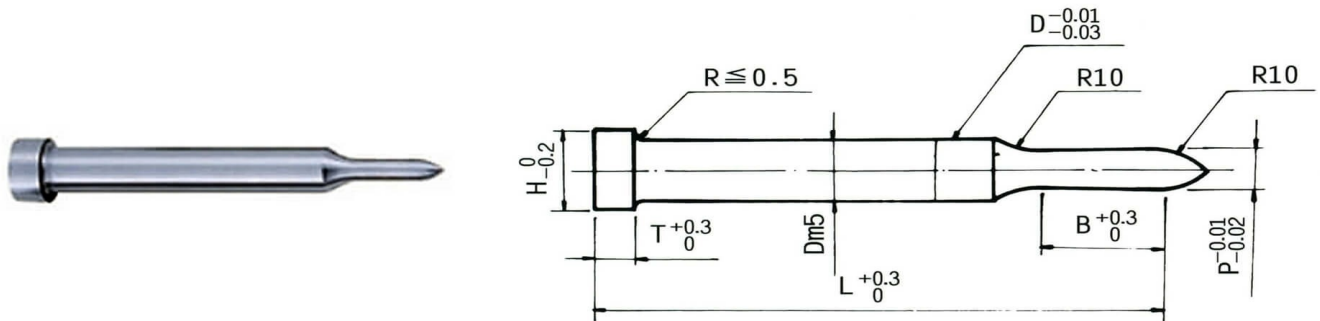

材質	傳統鋼材		粉末高速鋼					超硬碳化鎢		
	SKD-11	SKH-51	ASP-23	M4	ASP-60	T15	10V	G3	G4	G5
硬度	60~62	62~64	64~66	64~66	65~67	64~66	60~62	HRA87	HRA85	HRA84

型號	D	P	B	T	H	L	
B	4	1.5~2.4	8	4	6	40、50、60	
		2.5~3.4	10			40、50、60	
	5	2.0~2.4	8		7	40、50、60	
		2.5~3.4	10			40、50、60	
		3.5~4.4	12			40、50、60	
	6	3.0~3.4	10		8	40、50、60	
		3.5~4.4	12			40、50、60	
		4.5~5.4	15			40、50、60	
		5.5~5.9	15			40、50、60	
	8	6.0~7.9	15		5	10	40、50、60
	10	8.0~9.9	15			13	40、50、60

訂購方法：材質-型號-D X P X L X 數量
 例：10V-APP-6X2.5X50X20PCS

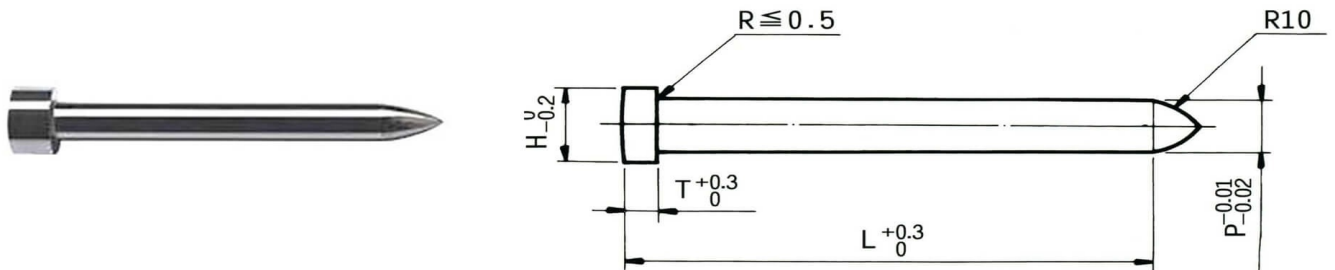

材質	傳統鋼材		粉末高速鋼					超硬碳化鎢		
	SKD-11	SKH-51	ASP-23	M4	ASP-60	T15	10V	G3	G4	G5
硬度	60~62	62~64	64~66	64~66	65~67	64~66	60~62	HRA87	HRA85	HRA84

型號	P	T	H	L
HB	2.0~2.9	4	4	40、50、60
	3.0~3.9	4	5	40、50、60
	4.0~4.9	4	6	40、50、60
	5.0~5.9	4	7	40、50、60
	6.0~6.9	4	8	40、50、60
	7.0~7.9	4	9	40、50、60、70
	8.0~8.9	5	10	40、50、60、70
	9.0~9.9	5	11	40、50、60、70
	10.0~10.9	5	13	40、50、60、70
	11.0~11.9	5	14	50、60、70、80
	12.0~12.9	5	15	50、60、70、80
	13.0~13.9	5	16	50、60、70、80

訂購方法：材質-型號-P X L 數量
 例：M4-BPP-5.3X50X20PCS

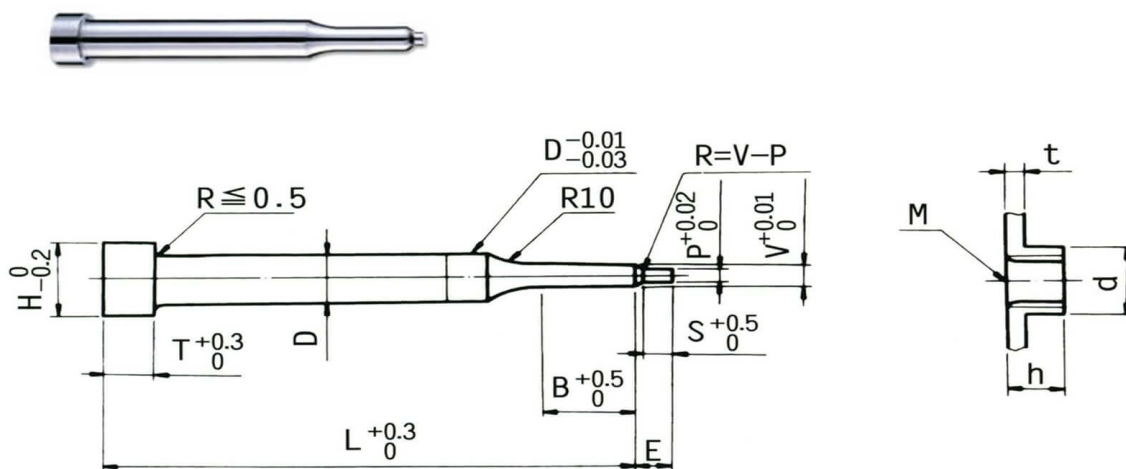

材質	傳統鋼材		粉末高速鋼					超硬碳化鎢		
	SKD-11	SKH-51	ASP-23	M4	ASP-60	T15	10V	G3	G4	G5
硬度	60~62	62~64	64~66	64~66	65~67	64~66	60~62	HRA87	HRA85	HRA84

型號	D	V	攻牙種類		抽孔部位		B	T	H	L
			m/m	英吋	p	s				
TAP	5	1.65	2		1	2	6	4	7	41、51
		2.2	2.6		1.3	2	6		7	41、51
		2.5 2.6 2.7	3	1/8"	1.5	2.5	8		7	41、51
		3	3.5		1.8	2.5	10		7	41、51
		3.2		5/32"	1.9	2.5	10		7	41、51
		3.4	4		2	3	10		7	41、51
	6	2.2	2.6		1.3	2	6		8	41、51
		2.5 2.6 2.7	3	1/8"	1.5	2.5	8		8	41、51
		3	3.5		1.8	2.5	10		8	41、51
		3.5		5/32"	1.9	2.5	10		8	41、51
		3.4	4		2	2.5	10		8	41、51
		3.6		3/16"	2.1	2.5	10		8	41、51
		3.8	4.5		2.2	2.5	10		8	41、51
	8	4.3	5		2.4	3	10		8	41、51
5.1		6	1/4"	2.6	3	10	5	10	41、51	

訂購方法：材質-型號-D X V X L X 數量
 例：10V-TAP-5X2.5X51X20PCS

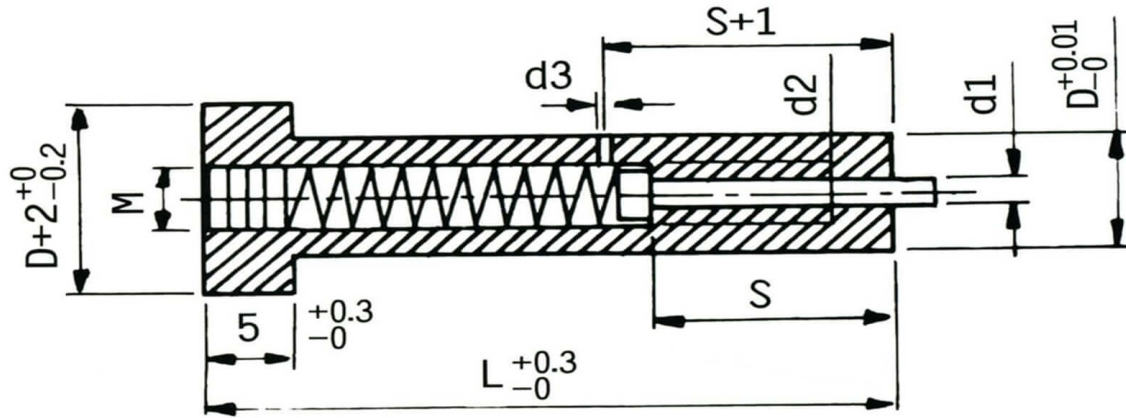

材質	傳統鋼材		粉末高速鋼				
		SKD-11	SKH-51	ASP-23	M4	ASP-60	T15
硬度	60~62	62~64	64~66	64~66	65~67	64~66	60~62

型號	d1	d2	d3	S	M	D	L
JP	1.1	2.1	1.0	13	2.5	4	40、50、60
				20		5	40、50、60
		2.6	3.4		27	3	6
		1.5		4.4			1.5
	1.8		36		5	10	
		2.8		4.4		1.5	36
	16		60、70、80				
	20		60、70、80、90				
	25		60、70、80、100				

訂購方法：型號-材質-D×L×數量
 例：JP-T15-8×60×10PCS

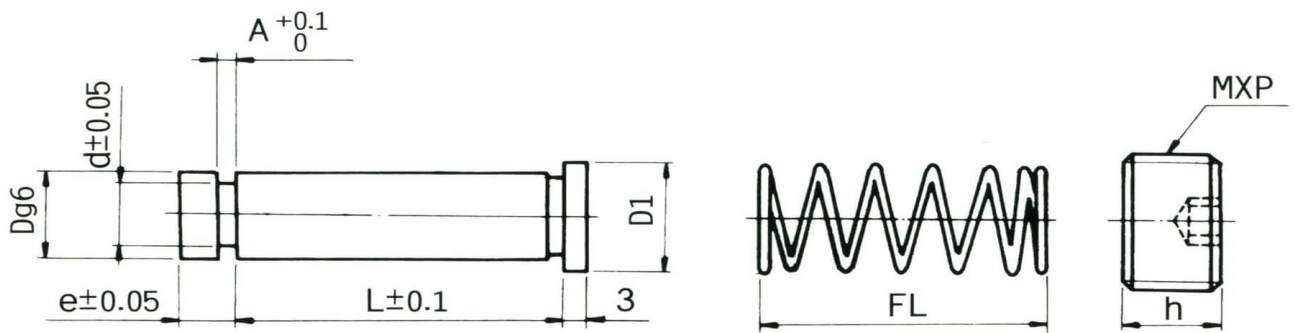

材質：SKD-11 HRC 60~62
SHK-51 HRC 62~64

M	8	10	12	16	20	22
P	1.25	1.5	1.5	1.5	1.5	1.5

型號	D	A	Dg6	d	e	D1	h	M	L
GLS	4	0.5 0.8	-0.004	2.0	5	6	8	8	22、25、28、30、33、36
	6	1.0 1.6	-0.012	3.6	7	8	10	10	22、25、28、30、33、36
	8	1.0 2.0	-0.005	5.0	7	10	10	12	22、25、28、30、33、36
	10	1.6 2.5	-0.014	6.0	7	13	10	16	25、28、30、33、36、40、50
	13	2.5 3.6	-0.006	7.0	7	16	12	20	28、30、33、36、40、50
	16	2.5 4.0	-0.017	8.0	12	19	12	22	30、33、36、40、50、60

訂購方法：材質-型號-D X A X L X數量
例：SKH51-GLS-8X1.0X30X20PCS

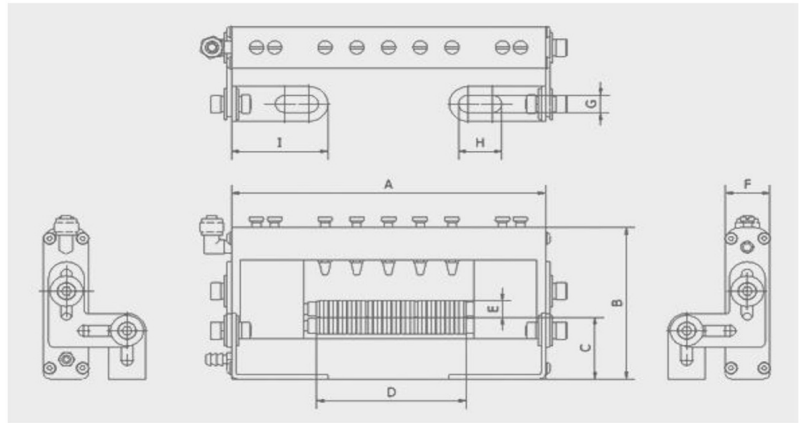

尺寸表

	A	B	C	D	E	E	G	H
BT-80	198	113	42	80	Ø22	31	13	30
BT-100	218	113	42	100	Ø22	31	13	30
B T-150	268	113	42	150	Ø22	31	13	30
BT-200	318	113	42	200	Ø22	31	13	30
BT-250	368	113	42	250	Ø22	31	13	30
BT-300	418	113	42	300	Ø22	31	13	30
BT-350	468	113	42	350	Ø22	31	13	30
BT-400	518	113	42	400	Ø22	31	13	30

規格表

	最大材料寬度(W)	板厚
BT-80	80 m/m	0.10~2.0 m/m
BT-100	100 m/m	0.10~2.0 m/m
B T-150	150 m/m	0.10~2.0 m/m
BT-200	200 m/m	0.10~2.0 m/m
BT-250	250 m/m	0.10~2.0 m/m
BT-300	300 m/m	0.10~2.0 m/m
BT-350	350 m/m	0.10~2.0 m/m
BT-400	400 m/m	0.10~2.0 m/m

特性

- 材料給油機適用於材料雙面能均勻塗佈，可大幅提升沖壓模具壽命。
- 機體結構採用鋁合金，經陽極表面處理可達到美觀耐用，搭配簡易固定座，適合各種機體安裝。
- 特殊微調式油量設計，油量大小可依說工作所需調整，達到節省油料浪費。
- 本機採用高密度羊毛氈，耐磨性強，含油性佳，採用片式組合設計，維修簡便。
- 油桶內裝有過濾網，潤滑油可重覆使用。
- 可選擇裝有電動泵浦的油桶，與沖床連接做自動化、無人化作業。
- 上滾輪採多樣化調整油量方式，可達到客戶需求。



產品特點

- SD-401 一台主機一個輸出點 (單點)
- SD-402 一台主機二個輸出點 (雙點)

使用說明

1. 感測器操作設定距離：為 (A) 位置 0.8mm 至 1.2mm，請按設定開關後出現 199 至 0，再移動感測鐵塊就可調整到 80~120 的操作距離。(也就是 0.8mm 至 1.2mm)。設定完成後需再按設定開關復原。
2. 監視值設定之操作：精密度設定範圍±1μm ~ ± 99μm，監視值依您實際需要的精度而設定。
3. 當沖模開始運作此檢知前四次顯示數字為模具高度測試平均值。(當沖床電源開關切掉“OFF”或感應線離開感應器再重新插入 感應器等，此值才會重新計算)。
4. 本機台有自我檢知功能。
5. 此機台規格設定值為 1 μm 單位，可依模具精度需要而選擇。
6. 此檢知可加裝誤送檢知、材料無料檢知 (電眼檢知)、擠料檢知 (感測棒檢知)。

規格表

適用溫度	0~50°C	標準配件	感測器、感測線 3M、鐵塊
重量	SD-401-2.2kg / SD-402-2.3kg	有線感測器長度	10 cm
輸出信號	繼電器接點 (A..B) 250V3A	連接線長度	3M 及 5M
電源電壓	AC85V~250V50/60Hz ±10%	感測設定距離	0.8mm~1.2mm
外形尺寸	105W*140H*185D	最大連轉速度	1200 S.P.M

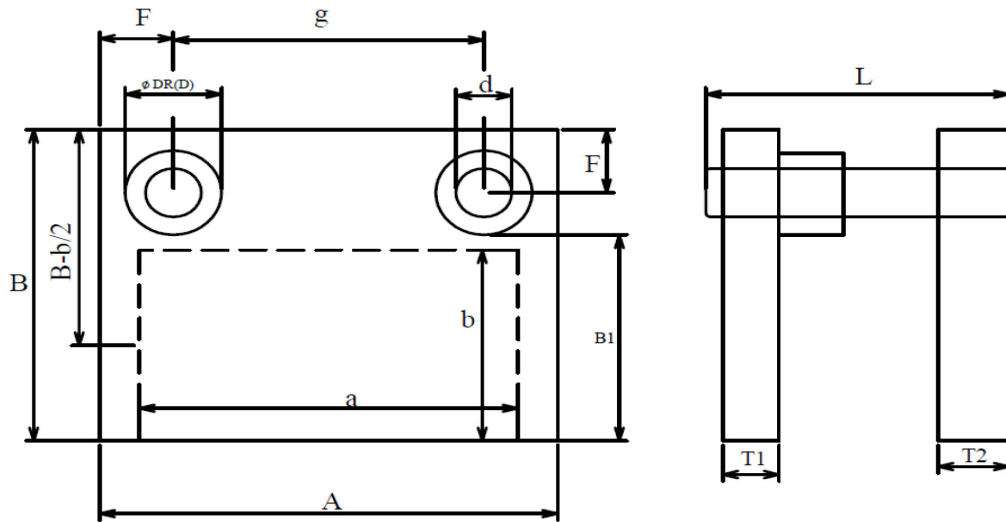

★ KBB型為不附鋼珠型
★ KBBB型為附鋼珠型

型號	a	b	A	B	g	F	T1	T2	d	D	DR	L
KBB KBBB	100	80	150	135	80	35						130
	100	100	150	155	80	35	25	30	22	35	40	
	125	100	175	155	100	35						
	125	125	175	185	100	35	30	35	25	35	44	140
	150		200	185	120	35						
	200		250	185	170	35						
	250	150	300	185	220	35	30	35	28	40	48	150
	150		200	225	120	40						
	200		250	225	160	40						
	250		300	225	210	40						
	300		350	225	260	40						
	350	400	225	310	40							
	200	200	250	270	170	42	35	40	32	44	54	180
	250		300	270	220	42						
	300		350	270	270	42						
	350		400	270	320	42						
	400		450	270	370	42						
	250	250	300	325	200	45	35	45	36	48	58	180
	300		350	325	250	45						
	350		400	325	300	45						
400	450		325	350	45							
450	500		325	400	45							

訂購方式：型號-a×b×數量
例如：KBBB-300×150×2組

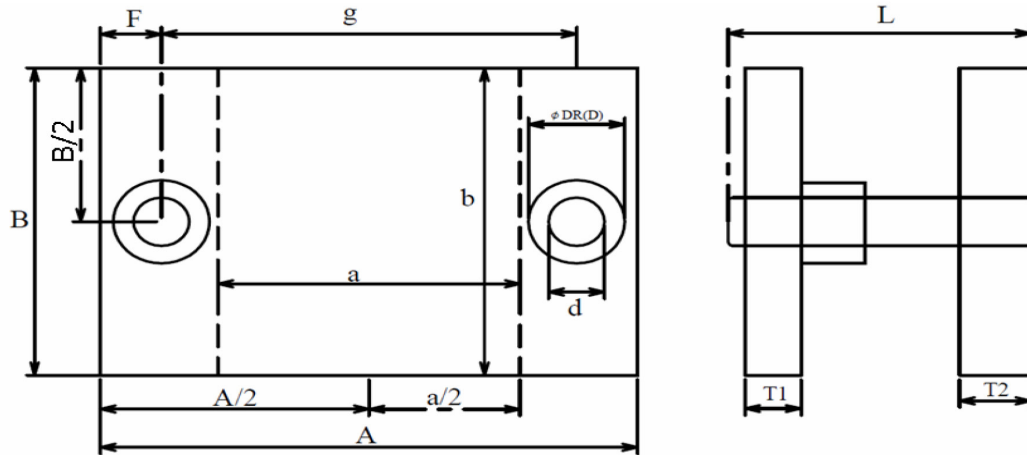

★ KCB型為不附鋼珠型
★ KCBB型為附鋼珠型

型號	a	b	A	B	g	T1	T2	d	D	DR	L
KCB KCBB	100	80	230	80	150						
	100	100	230	100	150	25	30	22	35	40	130
	125		255	100	175						
	125	125	265	125	180	30	35	25	35	44	140
	150		290	125	205						
	200		340	125	255						
	250		390	125	305						
	150	150	300	150	210	30	35	28	40	48	150
	200		350	150	260						
	250		400	150	310						
	300		450	150	360						
	350	200	500	160	410	35	40	32	44	54	180
	200		360	200	265						
	250		410	200	315						
	300		460	200	365						
	350	250	510	200	415	35	45	36	48	58	180
	400		560	200	465						
	250		420	250	320						
	300		470	250	370						
	350	250	520	250	420	35	45	36	48	58	180
400	570		250	470							
450	620		250	520							

訂購方式：型號-a×b×數量
例如：KCBB-300×200×3組

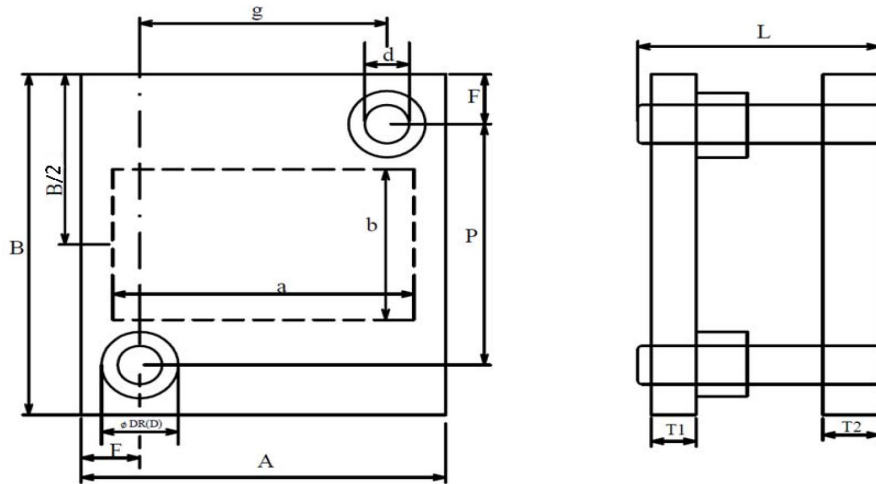

- ★ KDB型為不附鋼珠型
- ★ KDBB型為附鋼珠型

型號	a	b	A	B	g	P	F	T1	T2	d	D	DR	L
KDB KDBB	100	80	150	210	70	130	40	25	30	22	35	40	130
	100	100	150	230	70	150	40						
	125	100	175	230	95	150	40						
	125	125	175	265	90	180	43	30	35	25	35	44	140
	150		200	265	115	180	43						
	200		250	265	165	180	43						
	250		300	265	215	180	43						
	150	150	200	300	110	210	45	30	35	28	40	48	150
	200		250	300	160	210	45						
	250		300	300	210	210	45						
	300		350	300	260	210	45						
	350	200	400	300	310	210	45	35	40	32	44	54	180
	200		250	360	155	265	48						
	250		300	360	205	265	48						
	300		350	360	255	265	48						
	350	250	400	360	305	265	48	35	45	36	48	58	180
	400		450	360	355	265	48						
	250		300	420	200	320	50						
	300		350	420	250	320	50						
	350	250	400	420	300	320	50	35	45	36	48	58	180
400	450		420	350	320	50							
450	500		420	400	320	50							

訂購方式：型號-a×b×數量
 例如：KDBB-100×80×3組

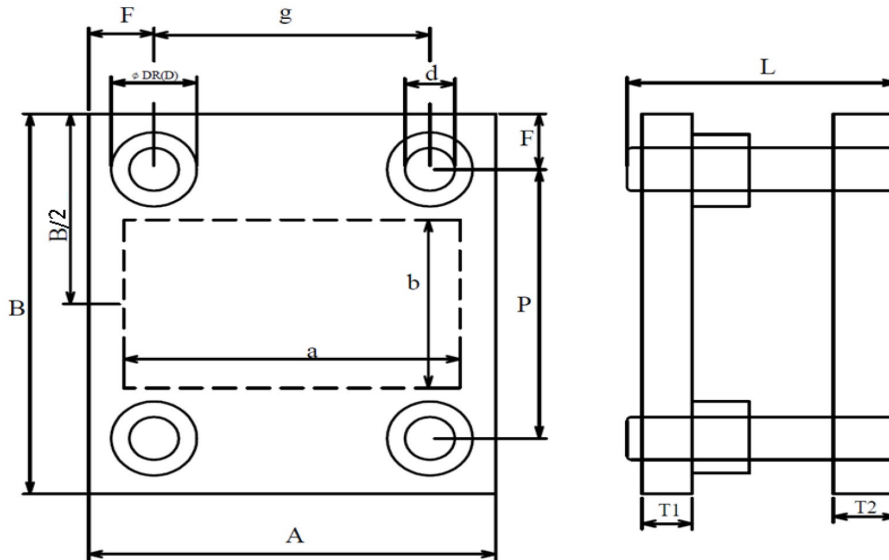

★ KFB型為不附鋼珠型
★ KFBB型為附鋼珠型

型號	a	b	A	B	g	P	F	T1	T2	d	D	DR	L
KFB KFBB	100	80	150	210	70	130							
	100	100	150	230	70	150	40	25	30	22	35	40	130
	125		175	230	95	150							
	125		175	265	90	180							
	150	125	200	265	115	180	43	30	35	25	35	44	140
	200		250	265	165	180							
	250		300	265	215	180							
	150		200	300	110	210							
	200	150	250	300	160	210	45	30	35	28	40	48	150
	250		300	300	210	210							
	300		350	300	260	210							
	350		400	300	310	210							
	200	200	250	360	155	265	48	35	40	32	44	54	180
	250		300	360	205	265							
	300		350	360	255	265							
	350		400	360	305	265							
	400		450	360	355	265							
	250	250	300	420	200	320	50	35	45	36	48	58	180
	300		350	420	250	320							
	350		400	420	300	320							
400	450		420	350	320								
450	500		420	400	320								

訂購方式：型號-a×b×數量
例如：KFBB-400×200×1組

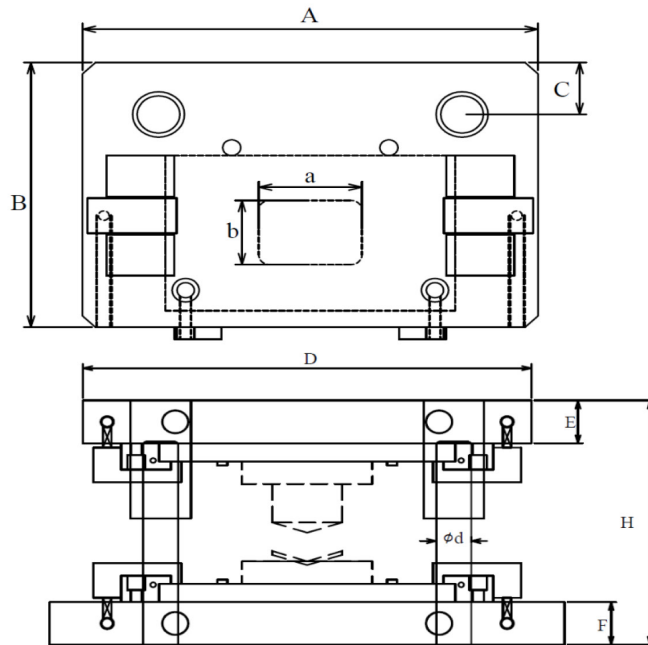

★ 任何特殊規格 · 均可訂製

型號	編號	模具尺寸	a×b	A	B	C	D	E	F	H	d
QDC	1	100*100	80*65	300	165	35	250	30	36	140	25
	2	125*125	100*80	340	190	35	280	30	38	140	25
	3	150*150	120*100	380	230	40	320	32	40	150	28
	4	180*180	150*135	420	260	40	360	36	42	150	28
	5	210*210	170*150	470	300	45	400	38	44	180	32

訂購方式：型號-編號×數量
 例如：QDC-3×1組

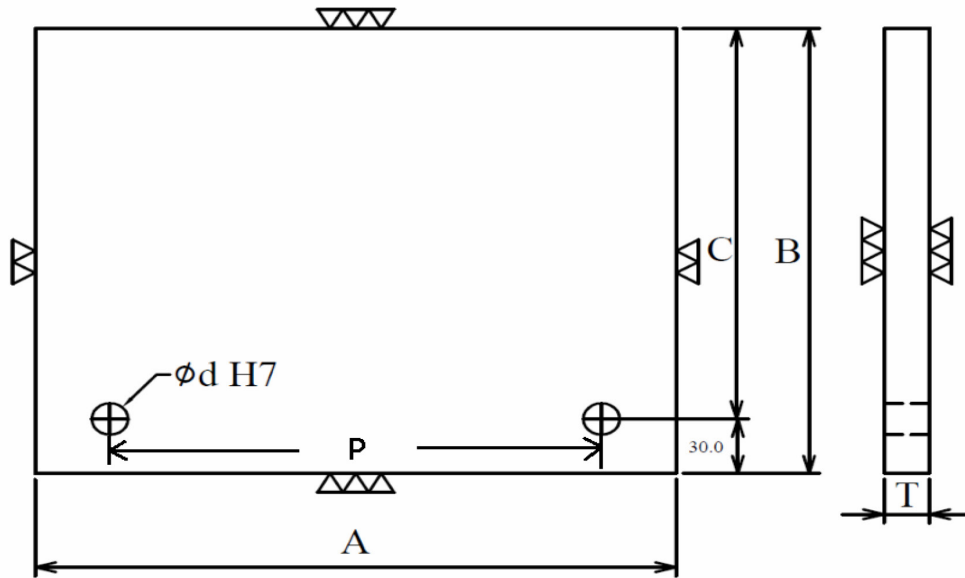

★材質：S50C

型號	QDC 適用規格	模具尺寸	A	B	C	P	T	φd (H7)
QDCP	1	100*100	150	100	70	120	15	15
	2	125*125	170	125	95	140	15	15
	3	150*150	200	150	120	170	18	16
	4	180*180	230	180	150	200	18	16
	5	210*210	262	210	180	226	22	16

訂購方式：型號-編號×數量
 例如：QDCP-2×10組



沖壓模具標準零組件

Standard Components of Stamping Die

凱泰精工股份有限公司

717 臺南市仁德區勝利路91號

電話：06-2796095

傳真：06-2703920

E-Mail：ktai@ktai.com.tw

